

Please read these instructions carefully as they will enable you to get maximum efficiency and reliability from your new Calorex Dehumidifier

Technical Manual
THROUGH THE WALL DEHUMIDIFIERS
TTW30(7)/33(7)/55(7)/60(7)
D373360 ISSUE 19
20/05/14

HEALTH AND SAFETY WARNING

As the dehumidifier embodies electrical and rotational equipment, ONLY competent persons should carry out any work on this type of machine. (See Guarantee).

Contents

1.0 INSTALLATION DETAILS	2
2.0 DATA SHEET	4
3.0 WIRING DIAGRAMS	5
4.0 PERFORMANCE GRAPHS	11
5.0 DIMENSIONS	14
6.0 SPARE PARTS LISTS	15
7.0 OPTIONAL KITS	39
7.1 12V REMOTE HUMIDISTAT KIT	39
7.2 LPHW ASSEMBLIES	41
8.0 WARRANTY CONDITIONS	42

1.0 INSTALLATION DETAILS

INSTALLATION INSTRUCTIONS MODELS TTW30/33/50/55/60/A/AX

HEALTH & SAFETY WARNING

As the Heat Pump contains electrical and rotational equipment, it is recommended that ONLY competent persons carry out any work on this type of machine (see guarantee) Isolate electrically before entering machine or removing panels. This appliance is not intended for use by persons (including children) with reduced physical, sensory or mental capabilities, or lack of experience and knowledge, unless they have been given supervision or instruction concerning use of the appliance by a person responsible for their safety. Children should be supervised to ensure that they do not play with the appliance

INSTALLATION MODELS TTW30/33/55/60.

1. Remove dehumidifier from packing.
2. Check both sides of wall, mark out apertures 'D' & 'E' in required location and ensure they are level.
3. Cut out apertures 'D' & 'E' with due consideration to structure and safety using asuitable lintel to bridge gap.
4. Remove the 4 off bolts holding dehumidifier to wall plate and also earth lead .
5. Locate wall plate in apertures and ensure level, drill and fix using 12 'C' holes and wall plugs/screws provided, hole size 6,0mm (No.10) x 60mm.
6. Lift dehumidifier up on to wall and replace 6 off M6 bolts and wall plate earth lead.
7. Fix supplied cavity bridging pieces and air inlet/outlet grilles, ensure all joints sealed with silicon caulking.

	'D' APERTURE	'E' APERTURE
TTW33	85 high x 520 long	110 high x 520 long
TTW55	85 high x 980 long	110 high x 980 long

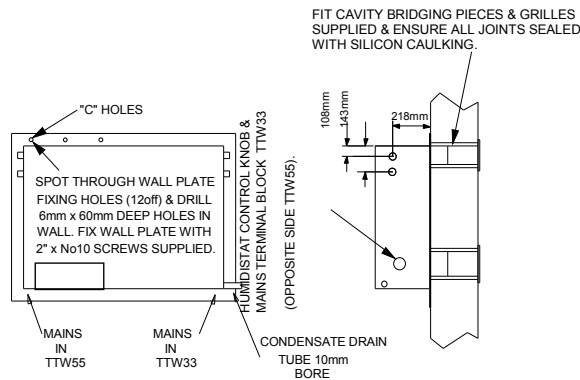
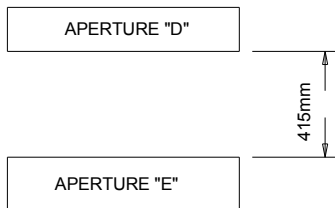

PLANT ROOM VIEW OF MACHINE

8. Electrical supply to the unit must be sized according to the data on the serial number label paying special attention to I.E.E. regulations latest edition regarding the special conditions governing the supply to machines in potentially damp areas.
9. The electrical supply should be connected to the terminal block. Brown/red to 'live', blue/black to neutral, and earth to the stud provided.
10. Fan mode switch can be set to cycle fan when humidistat senses demand but should be set to continuous to promote good air circulation and reduce condensation. Note that on models fitted with LPHW the fan(s) will start automatically whenever there is an air heating demand. On 'X' machines fan(s) will stop during defrost cycle.

11. Locate pipe from drip tray and run away to waste, a short length of 10mm pipe is provided which should be led into a fixed waste pipe (ensure an air gap, tun dish).

MODELS WITH L.P.H.W. FITTED

12. Connect water circuit piping to 15mm stubs projecting from side of machine as per diagram below:-
13. It is recommended that isolating valves are fitted to enable isolation of the machine in the event of service. Complete water circuit as per diagrams overleaf. (a) Circulating pump must be sized to take into account the design flow rate of the machine plus the water system resistance.

	TTW30/33	TTW55/60
Unit Flow Rate - l/min	5.0	5.0
Unit Pressure Drop - m head	1.1	1.8

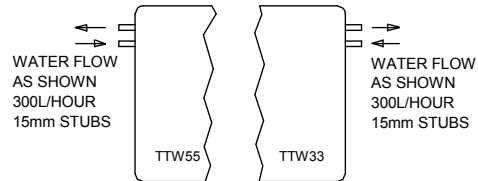

PLANT ROOM VIEW OF MACHINE

12v REMOTE HUMIDISTAT CONNECTIONS

14. Remove link wire from mains in terminal block marked 'Remote Control Interface'. Connect remote humidistat as shown below, ensure knob on humidistat in machine is set fully clockwise (ie maximum dehumidification).

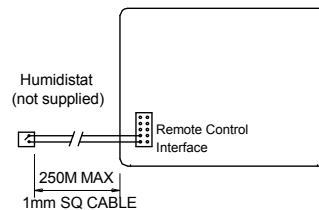

15. Refit all brown covers, ensure mains lead and drain tube are not obstructed, and turn humidistat clockwise (ie maximum dehumidification)

'P' MODELS WITH RESISTANCE HEATER

16. Connect remote air thermostat to terminal block marked 'Remote Control Interface'.
17. Ensure safety thermostat(s) are set, ie push red button(s) inside machine. Remove cover to gain access.
18. Replace front cover, (unless remote humidistat fitted, see note 14 above) unit will start, following 6 minutes later by the compressor.

ELECTRICAL SUPPLY CIRCUITS

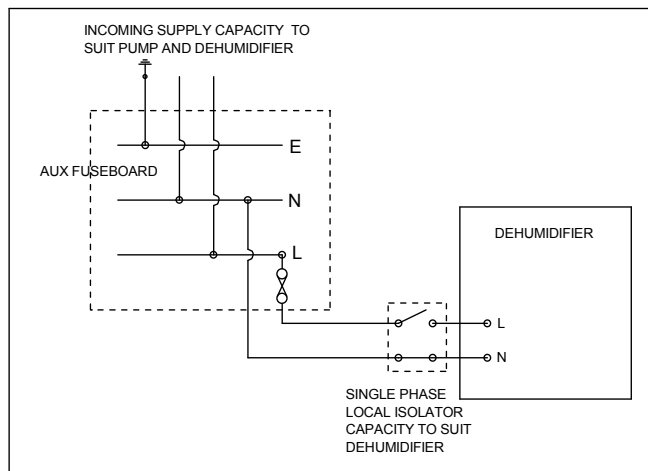

LPHW PLUMBING SCHEMATIC

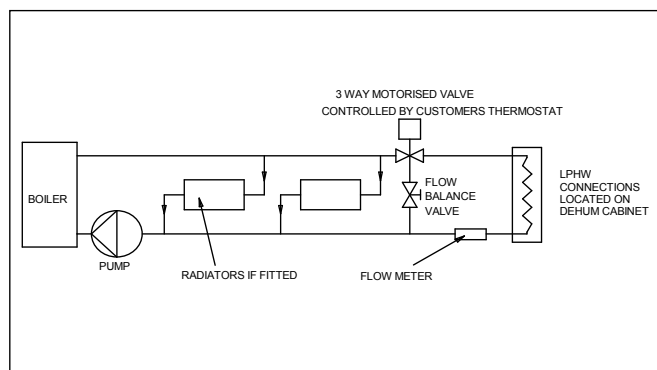

GAS CHARGE

The dehumidifier incorporates a hermetically sealed refrigeration circuit containing less than 6kg of refrigerant R407c. Global warming potential (GWP) 1700.

USER CHECK LIST

OPERATION

A normal humidistat setting (50-60% RH) is a mid way point on the knob provided.

Minimum Air Temp TTW 30/33/55/60 A = 15°C

Minimum Air Temp TTW 30/33/55/60 AX = 0°C

Note :- On 'X' models fan stops during defrost.

On machines with LPHW, fans will start automatically as required.

MAINTENANCE

a. Ensure air inlet/outlets are kept clear and clean.

b. Wipe clean with damp cloth or cleaning fluid suitable for plastic coated steel

Note: The Reply Paid Warranty Registration Card must be returned to ensure the correct warranty is given. If you do not find a Registration Card with your machine please contact CALOREX Service Department giving your name address and serial number of your machine. A card will then be sent to you for completion.

HEALTH & SAFETY WARNING

As the Heat Pump contains electrical and rotational equipment, it is recommended that ONLY competent persons carry out any work on this type of machine (see guarantee)

Isolate machine electrically before entering machine or removing panels.

MACHINE NOT RUNNING AT ALL

CHECK THE FOLLOWING :-

1. Is supply switched on.
2. Is supply fuse healthy
3. Turn humidistat knob fully clockwise.
4. Check air inlet and outlet for obstructions.
5. If, after carrying out the above and waiting 1 hour, the machine does not start phone for service.

MACHINE FAN ONLY RUNNING

6. Turn humidistat knob fully clockwise
7. Check air inlet and outlet for obstructions, if after 30 mins the machine has not restarted phone for service.

WATER LEAKING FROM BASE OF UNIT

8. Check connection from machine to drain for blockages and clear accordingly. Check fall is adequate.
9. Check that machine is level both vertically and horizontally. The user check list should be carried out before initiating a service call. Do not attempt to interfere with any internal control settings as these have been factory calibrated and sealed. If in doubt or if advice is required, contact Calorex Service Dept. Telephone (01621) 857171 or 856611

PLEASE LEAVE INSTRUCTIONS FOR USER

2.0 DATA SHEET

MODEL		TTW33(7)/30(7)A	TTW33(7)/30(7)AX	TTW30(7)AP/AXP	TTW55(7)/60(7)A	TTW55(7)/60(7)AX	TTW50(7)AP/AXP
DEHUMIDIFICATION	L/hr	1.25	1.25	1.25	2.5	2.5	2.5
	L/day	30.0	30.0	30.0	60.0	60.0	60.0
TOTAL HEAT TO AIR :-							
DEHUMIDIFIER ONLY	kW	1.9	1.9	1.9	3.5	3.5	3.5
DEHUM & RESISTANCE HEATER	kW	n/a	n/a	2.89	n/a	n/a	5.55
RESISTANCE HEATER ONLY	kW	n/a	n/a	2.0	n/a	n/a	4
DEHUM & LPHW	kW	3.9	3.9	n/a	6.5	6.5	n/a
LPHW ONLY	kW	3.0	3.0	n/a	5.0	5.0	n/a
NOMINAL POWER CONSUMED:-							
FAN ONLY	kW	0.05	0.05	0.05	0.1	0.1	0.1
DEHUM (COMP & FAN)	kW	0.75	0.75	0.75	1.2	1.2	1.2
DEHUM & HEATER	kW	n/a	n/a	2.75	n/a	n/a	5.2
HEATER & FAN	kW	n/a	n/a	2.05	n/a	n/a	4.1
SUPPLY		230V 50Hz	230V 50Hz	230V 50Hz	230V 50Hz	230V 50Hz	230V 50Hz
FUSE	AMP	10.0	10.0	20.0	13.0	13.0	32.0
NOMINAL RUNNING	AMP	3.4	3.4	11.7	5.6	5.6	22.3
FULL LOAD AMPS	AMP	4.4	4.4	12.7	7.5	7.5	24.2
COMPRESSOR L.R.A.	AMP	15.8	15.8	15.8	30	30	30
AIR FLOW	m ³ /h	420	420	420	750	750	750
NOISE LEVEL @ 3m	dB(A)	46	46	46	47	47	47
LPHW FLOW RATE	L/min	5.0	5.0	n/a	5.0	5.0	n/a
LPHW PRESSURE DROP	mhd	1.1	1.1	n/a	1.8	1.8	n/a
HERMETIC SYSTEM							
REFRIGERANT CHARGE	kg R407c	0.5	0.4	0.5(30AP) 0.45(30AXP)	0.75	0.8	0.75 AP 0.8 AXP
WEIGHT (UNPACKED/PACKED)	kg	45 / 55	45 / 55	45 / 55	70 / 85	70 / 85	70 / 85

See note d

NOTES:-

- These performance figures are based on air @ 30°C and 60% RH & pool water @ 28°C, Boiler water at 80°C
- Humidistat adjustable from 20% to 80%
- Minimum air temperature on standard models 15°C and 0°C on defrost 'X' models
- Reduced LPHW output when DH operating is 1kW less on 33 model and 2kW less on 55 model
- IP rating for all models is IP45
- Maximum operating conditions air temp 35°C and 90% RH
- Maximum operating conditions for AP versions air temp 32°C and 62% RH

1mm Wg = 9.8 Pa
1m hd = 1.4 psi
1L/min = 0.22 gal/min

R407c Global Warming Potential (GWP) 1700

3.0 WIRING DIAGRAMS

DRG No. D372750

IF IN DOUBT ASK

DO NOT SCALE PRINT OVERLOAD PROTECTOR

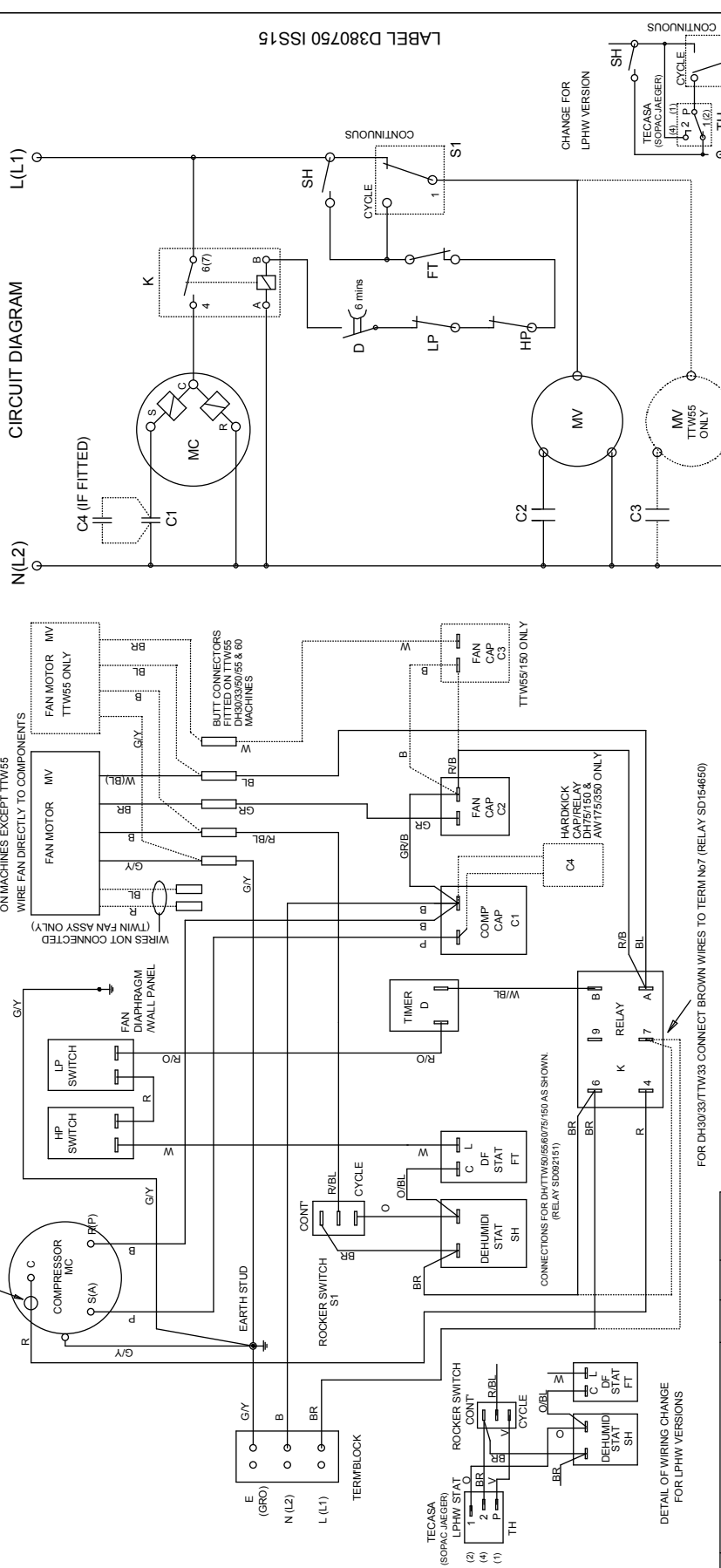

ISS	DESCRIPTION	CIN	APPD	DATE
18	FOR DH30/33/TTW33 RELAY SD154650 WAS SDZ16250	1967	PJ	09/01/13
17	RELAY 219250 WAS 154650	1642	KW	18/09/11
16	WIRE COLOUR REFS CLARIFIED	1643	KW	10/08/11
15	SCHRAK & FINDER DELETED FROM RELAY	1477	GSM	17/06/10
14	TECASA NOTE ADDED	11671	DH	28/08/07
13	BUTT CONNECTOR NOTE MODIFIED	1173	MDW	24/07/07
12	INTERCONTROL WIRING ADDED	1167	DH	17/05/07
11	LPHW SWITCH TERMINAL CHGD	1167	BJS	24/05/04
10	BUTTS USED ON TTW55 ONLY	1056	CJW	25/09/03
9	HARD KICK CAP ADDED	982	GSM	05/11/98
8	RELAY NOTE CHANGED	955	GSM	29/06/96
7	RELAY CHANGED	955	GSM	18/05/98

SH	FT	TH	S1	LP	HP	D	K	MC	C1	C2/C3	C4	A	T
BLACK	BL	BLUE	B	BROWN	BR	ORANGE	O	PINK	P	RED	R	WHITE	W
BLAU	B	BLAN	B	BRAUN	BR	ORANGE	O	ROSA	R	ROU	R	WEISS	W
NOIR	SH	BLEU	S1	MARRON	LP	ORANGE	RELAYS	ROSE	MC	ROU	FT	BLANC	C1
SWARZ	FT	BLEU	TH	BRUN	HP	ORANGE	RELAYS	ROSE	MC	ROU	FT	BLANC	C1
NOIR	FT	BLEU	TH	BRUN	HP	ORANGE	RELAYS	ROSE	MC	ROU	FT	BLANC	C1
SWARZ	FT	BLEU	TH	BRUN	HP	ORANGE	RELAYS	ROSE	MC	ROU	FT	BLANC	C1
NOIR	FT	BLEU	TH	BRUN	HP	ORANGE	RELAYS	ROSE	MC	ROU	FT	BLANC	C1

colorex

U.C.C.

© CALOREX HEAT PUMPS LTD

DRG No.	ISS	SH	NO	CONT	DRAWN	APPD	DATE	SCALE
D372750	1	1	---	GSM	D372750	30.05.95	NTS	

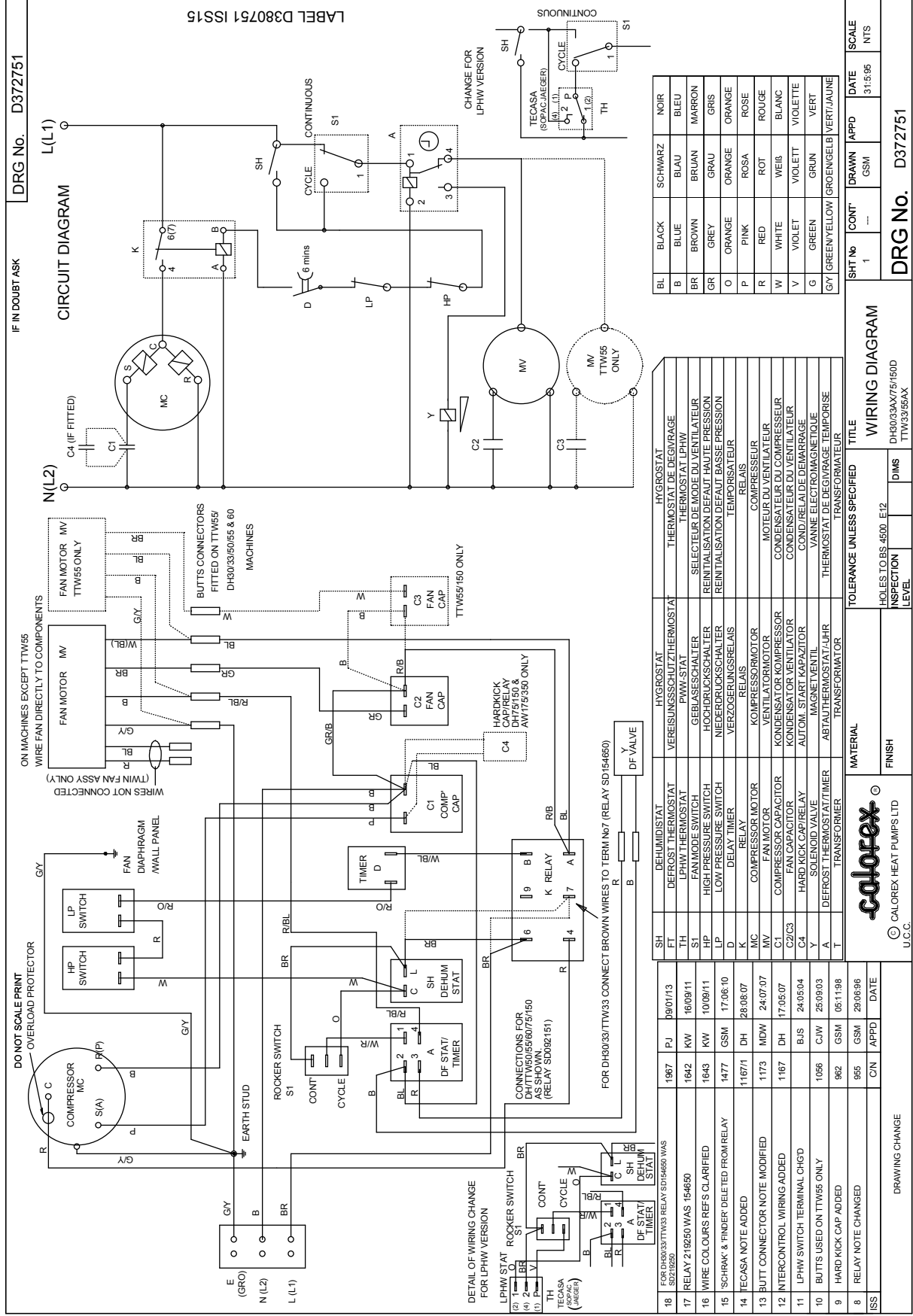

CIRCUIT DIAGRAM

IF IN DOUBT ASK **DRG No. D372752**

ON MACHINES EXCEPT T1W55
WIRE FAN DIRECTLY TO COMPONENTS
(TWIN FAN ASS ONLY)

FAN MOTOR MV
T1W55 ONLY

COMPRESSOR MOTOR
MC

RELAY R
12V COIL

TRANSFORMER T
12x

WIRING FOR T1W55 MACHINES:
FAN MOTOR MV, T1W55 ONLY
BUTT CONNECTORS FITTED ON T1W55/ DH903350/65 & 80 MACHINES
FAN CAP C2
COMP' CAP C1
HARDKICK CAP/RELAY DH75/150 & MW175/350 ONLY
T1W55/150 ONLY

WIRING FOR LPHW VERSIONS:
RELAY SD154650
ROCKER SWITCH CONT AS SHOWN
DEHUMID STAT S1
DEFROST THERMOSTAT
HYGROSTAT

DETAIL OF WIRING CHANGE FOR LPHW VERSIONS

LPHW STAT
ROCKER SWITCH CONT AS SHOWN
DEHUMID STAT S1
DEFROST THERMOSTAT
HYGROSTAT

OVERLOAD PROTECTOR DO NOT SCALE PRINT

FAN MOTOR MV

RELAY R

COMPRESSOR MOTOR MC

DEHUMID STAT

DEFROST THERMOSTAT

HYGROSTAT

TRANSFORMER T

RELAY K

RELAY D

RELAY A

RELAY B

RELAY C

RELAY E

RELAY F

RELAY G

RELAY H

RELAY I

RELAY J

RELAY K

RELAY L

RELAY M

RELAY N

RELAY O

RELAY P

RELAY Q

RELAY R

RELAY S

RELAY T

RELAY U

RELAY V

RELAY W

RELAY X

RELAY Y

RELAY Z

WIRING DIAGRAM

TOLERANCE UNLESS SPECIFIED

HOLES TO BS 4500 E12

INSPECTION LEVEL

colorex

CALOREX HEAT PUMPS LTD

U.C.C.

DRG No. D372752

SCALE NTS

DATE 2-11-98

DRWN APPD GSM

CONTRACT ---

DRG No. D372752

SHIT No 1

TITLE WIRING DIAGRAM
DH9033AARRH/75/150
T1W33/55A
WITH REMOTE HUMIDISTAT

DRG No. D372752

BL	BLACK	SCHWARZ	NOIR
B	BLUE	BLAU	BLEU
BR	BROWN	BRAUN	MARRON
GR	GREY	GRAU	GRIS
O	ORANGE	ORANGE	ORANGE
P	PINK	ROSA	ROSE
R	RED	ROT	ROUGE
V	WHITE	WEISS	BLANC
W	VIOLET	VIOLETT	VIOLETTE
G	GREEN	GRUN	VERT
GY	GREEN/YELLOW	GROEN/GELB	VERT/JAUNE

SH	DEHUMIDISTAT	HYGROSTAT	HYGROSTAT
FT	DEFROST THERMOSTAT	VEREISUNGSSCHUTZ/THERMOSTAT	THERMOSTAT DE DEGRIVAGE
S1	LPHW DEHUMIDISTAT	HYGROSTAT	HYGROSTAT LPHW
S2	FAN MOTOR	GEBLASENSCHALTER	SELECTEUR MOTEUR VENTILATEUR
LP	HIGH PRESSURE SWITCH	HOCHDRUCKSCHALTER	REINITIALISATION DEF/AUT HAUTE PRESSION
L	LOW PRESSURE SWITCH	NIEDERDRUCKSCHALTER	REINITIALISATION DEF/AUT BASSE PRESSION
D	DELAY TIMER	VERZOEGERUNGSRELAIS	TEMPORISATEUR
K	RELAY	RELAIS	RELAIS
MC	COMPRESSOR MOTOR	KOMPRESSORMOTOR	KOMPRESSEUR
MV	FAN MOTOR	VENTILATORMOTOR	MOTEUR DU VENTILATEUR
C1	COMPRESSOR CAPACITOR	KONDENSATOR KOMPRESSOR	KONDENSATEUR DU COMPRESSEUR
C2/C3	FAN CAPACITOR	KONDENSATOR VENTILATOR	KONDENSATEUR DU VENTILATEUR
C4	HARD KICK CAP/RELAY	AUTOM START KAPAZITOR	COND/RELAJ DE DEMARRAGE
Y	SOLENOID VALVE	MAGNE VENTIL	VANNE ELECTROMAGNETIQUE
A	DEFROST THERMOSTAT/TIMER	ABTAUTHERMOSTAT/JHR	THERMOSTAT DE DEGRIVAGE TEMPORISE
T	TRANSFORMER	TRANSFORMATOR	TRANSFORMATEUR

ISS	REV	DESCRIPTION	DATE	BY	APPD
17		FAN MOTOR RELAY SD154650 WAS	08/01/13	PJ	
16		RELAY 219250 WAS 154650	18/09/11	KW	
15		WIRE COLOUR REFS CLARIFIED FROM RELAYS	10/08/11	KW	
14		TECASA NOTE ADDED	17/08/10	GSM	
13		BUTT CONNECTION NOTE MODIFIED	28/08/07	DH	
12		INTERCONTROL WIRING ADDED	24/07/07	MDW	
11		LPHW SWITCH TERMINAL CHGD	17/05/07	DH	
10		DEHUMID STAT S1	24/05/04	BJS	
9		BUTTS USED ON T1W55 ONLY	25/09/03	CJW	
8		BUTTS ADDED FOR TRANS ON P.B.	08-11/02	CJW	

DRAWING CHANGE

C/N	APPD	DATE
1015	CJW	08-11/02

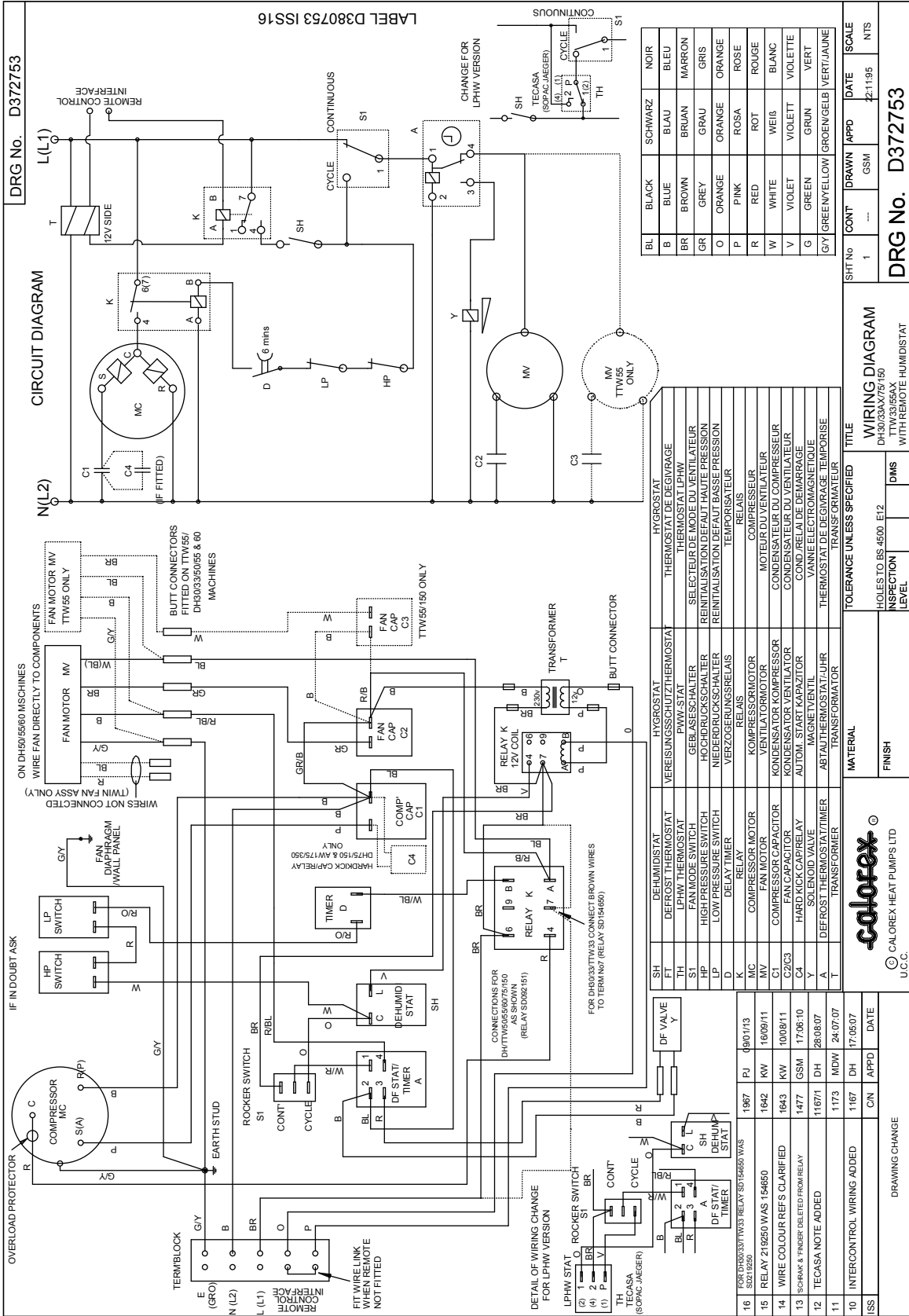

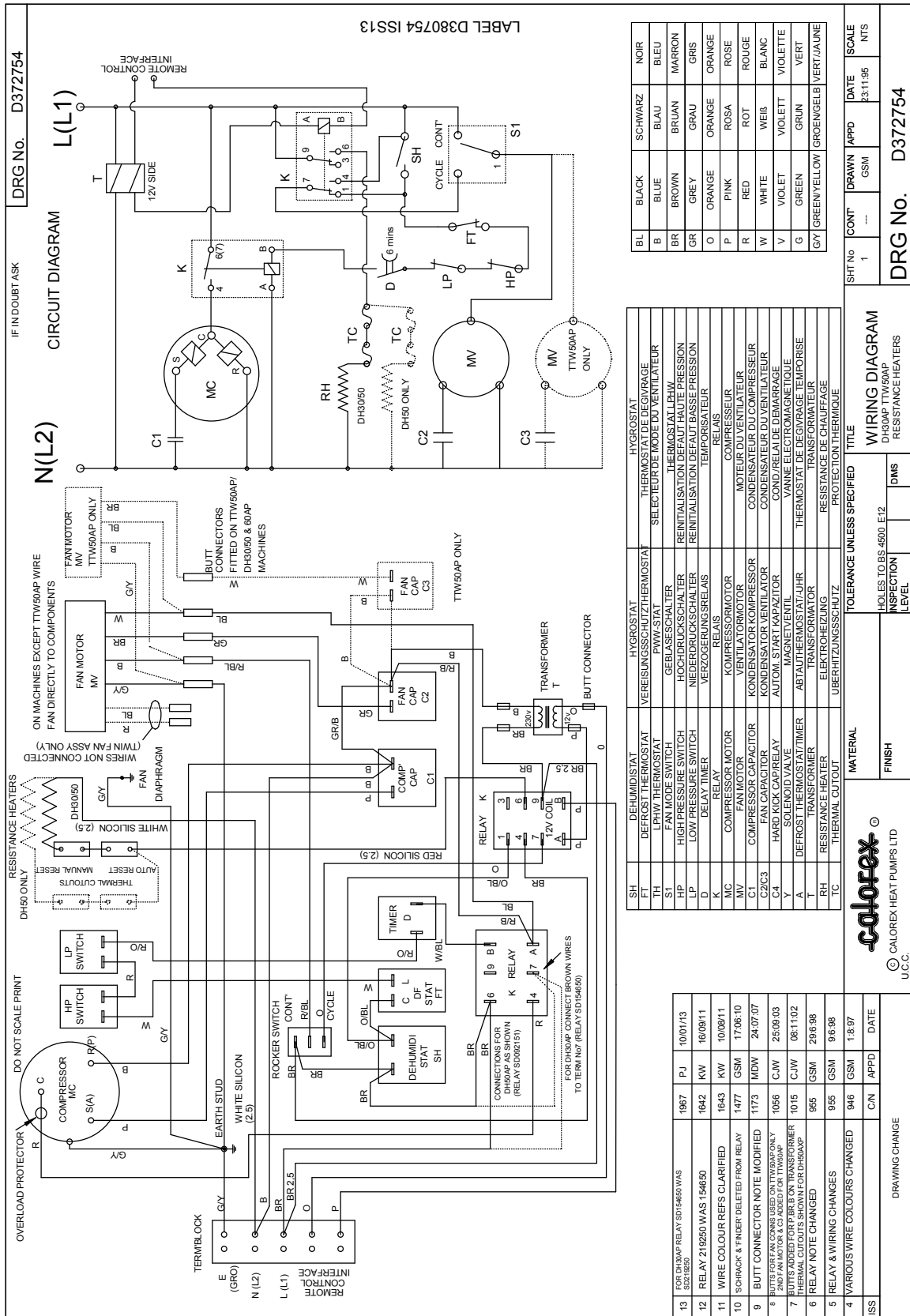

BL	BLACK	SCHWARZ	NOIR
B	BLUE	BLAU	BLEU
BR	BROWN	BRAUN	MARRON
GR	GREY	GRAU	GRIS
O	ORANGE	ORANGE	ORANGE
P	PINK	ROSA	ROSE
R	RED	ROT	ROUGE
W	WHITE	WEISS	BLANC
V	VIOLET	VIOLETT	VIOLETTE
G	GREEN	GRÜN	VERT
GY	GREEN/YELLOW	GRÜNGELB	VERT/JAUNE

SH	DEHUMIDISTAT	INGROSTAT	INGROSTAT
TH	DEFROST THERMOSTAT	VEREISUNGSSCHUTZ	THERMOSTAT GUYRAGE
TI	DELAY THERMOSTAT	PAUSE START	SELECTEUR DE MODE DU VENTILATEUR
SP	FAN MODE SWITCH	GEBIÄRESCHALTER	THERMOSTAT LEHM
HP	HIGH PRESSURE SWITCH	HOCHDRUCKSCHALTER	REINITIALISATION DEFAULT HAUTE PRESSION
LP	LOW PRESSURE SWITCH	NIEDERDRUCKSCHALTER	REINITIALISATION DEFAULT BASSE PRESSION
D	DELAY TIMER	VERZÖGERUNGSELEKTRONIK	TEMPORISATEUR
K	RELAY	RELE	RELE
MC	COMPRESSOR MOTOR	KOMPRESSORMOTOR	KOMPRESSEUR
MV	FAN MOTOR	VENTILATORMOTOR	MOTEUR DU VENTILATEUR
C1	COMPRESSOR CAPACITOR	KONDENSATOR KOMPRESSOR	KONDENSATEUR DU COMPRESSEUR
C2/C3	FAN CAPACITOR	KONDENSATOR VENTILATOR	KONDENSATEUR DU VENTILATEUR
C4	HARD KICK CAP/RELAY	AUTOM. START KAPAZITOR	COND./RELAIE DE DEMARRAGE
Y	SOLENOID VALVE	MAGNETVENTIL	VANNE ELECTROMAGNETIQUE
A	DEFROST THERMOSTAT/TIMER	ABTAU-THERMOSTAT/ZEIT	THERMOSTAT DE DEGIVRAGE TEMPORISE
T	TRANSFORMER	TRANSFORMATOR	TRANSFORMATEUR
RH	RESISTANCE HEATER	ELEKTROHEIZUNG	RESISTANCE DE CHAUFFAGE
TC	THERMAL CUT-OUT	ÜBERHITZUNGSSCHUTZ	PROTECTION THERMIQUE

13	FOR DH30AP RELAY SD154650 WAS SD218250	1987	PJ	10/01/13
12	RELAY 2119250 WAS 154650	1642	KW	16/09/11
11	WIRE COLOUR REFS CLARIFIED	1643	KW	10/08/11
10	SCHRACK & FINDER DELETED FROM RELAY	1477	GSM	17/06/10
9	BUTT CONNECTOR NOTE MODIFIED	1173	MDW	24/07/07
8	RELAY NOTE CHANGED FOR THERMAL CUT-OUTS SHOWN FOR DH30AP	1056	CJW	25/09/03
7	RELAY NOTE CHANGED FOR DH30AP	1015	CJW	08/11/02
6	RELAY NOTE CHANGED	955	GSM	29/6/98
5	RELAY & WIRING CHANGES	955	GSM	9/6/98
4	VARIOUS WIRE COLOURS CHANGED	946	GSM	1/8/97

SHT No	1	CONT	---	DRAWN	GSM	DATE	23/11/95	SCALE	NTS
--------	---	------	-----	-------	-----	------	----------	-------	-----

TITLE	
WIRING DIAGRAM	
DH30AP TTW50AP	
RESISTANCE HEATERS	

TOLERANCE UNLESS SPECIFIED	
HOLES TO BS.4500 E12	
INSPECTION	DIMS
LEVEL	

MATERIAL	
FINISH	

DRAWING CHANGE		
CIN	APPD	DATE



4.0 PERFORMANCE GRAPHS

TTW30/33/30(7)/33(7) PERFORMANCE.

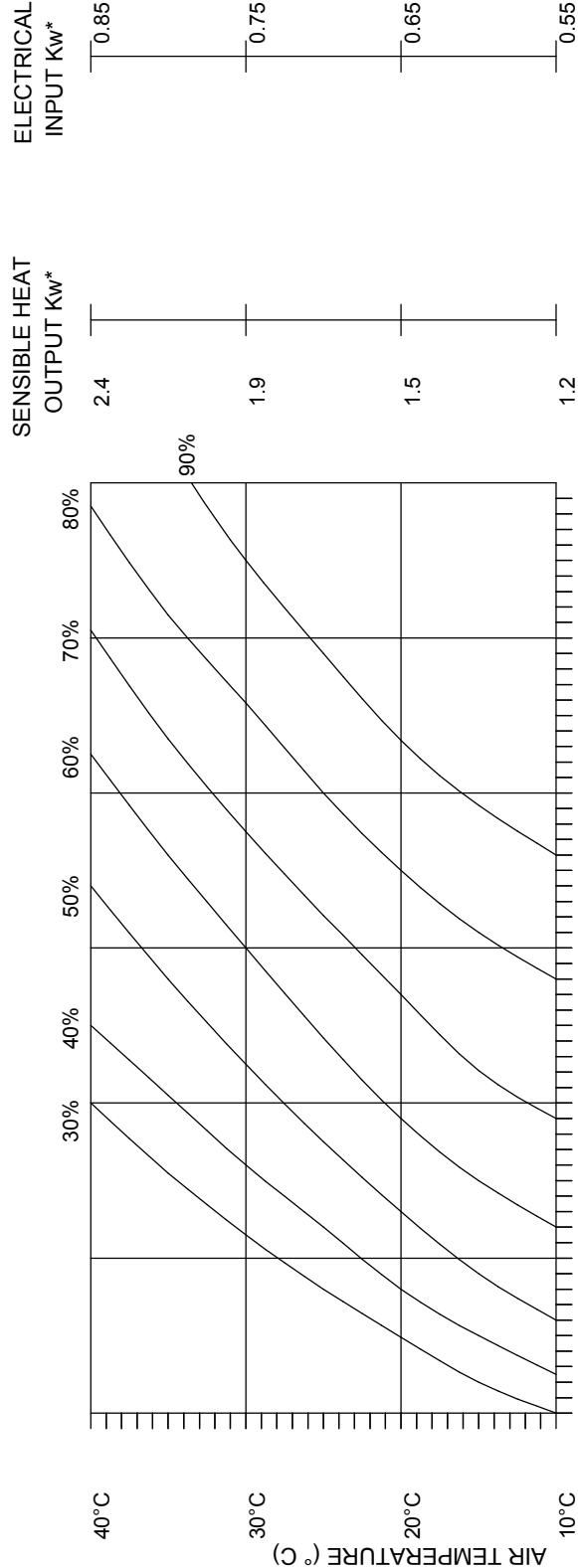

* = AT 60%RH

MAX OPERATING TEMP 40°C (R22)
 MAX OPERATING TEMP 35°C (R407c)

TTW55/55(7)/60/60(7) PERFORMANCE.

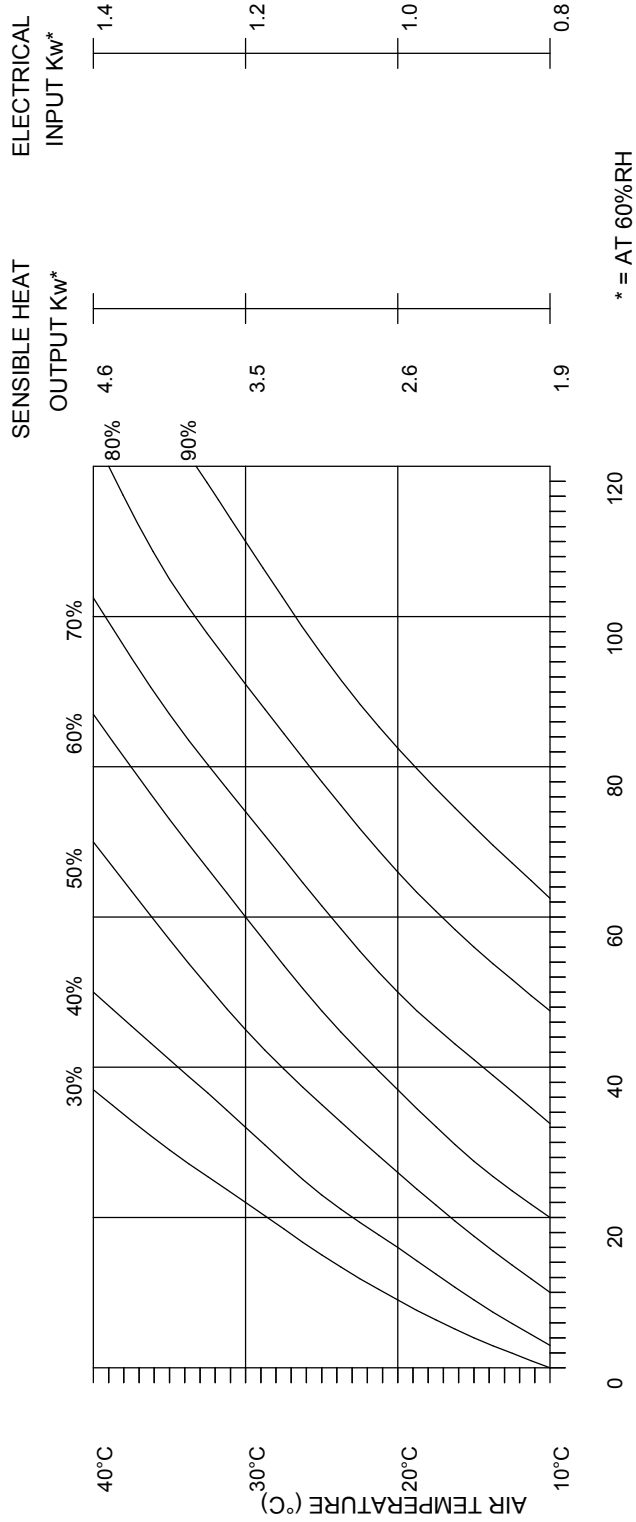

MOISTURE EXTRACTION LITRES/24HOURS

MAX OPERATING TEMP 40°C (R22)

MAX OPERATING TEMP 35°C (R407c)

4.0 CONT

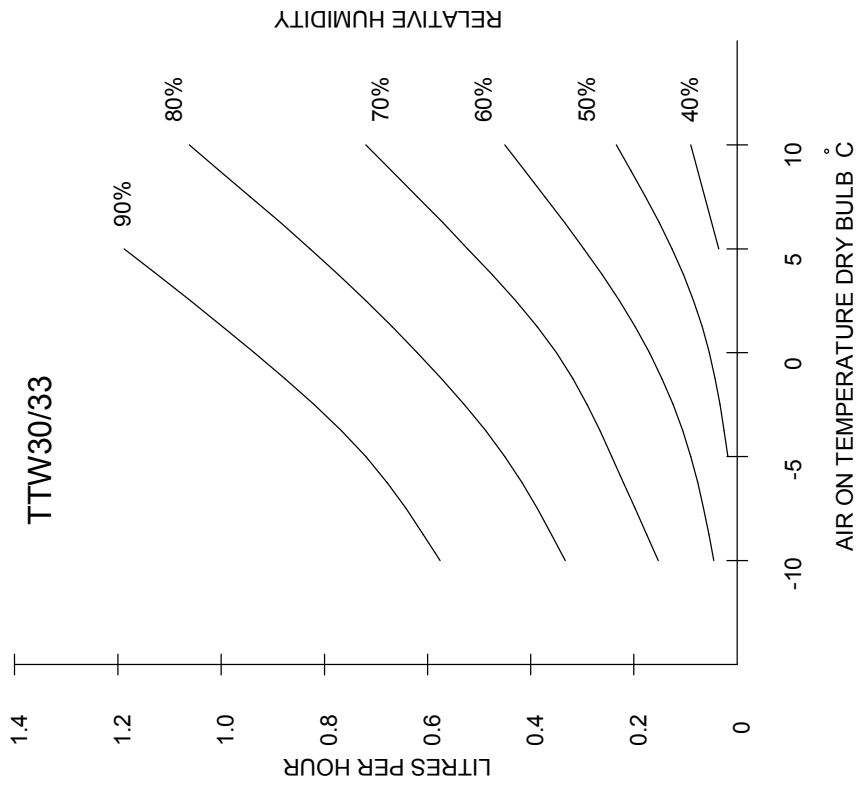
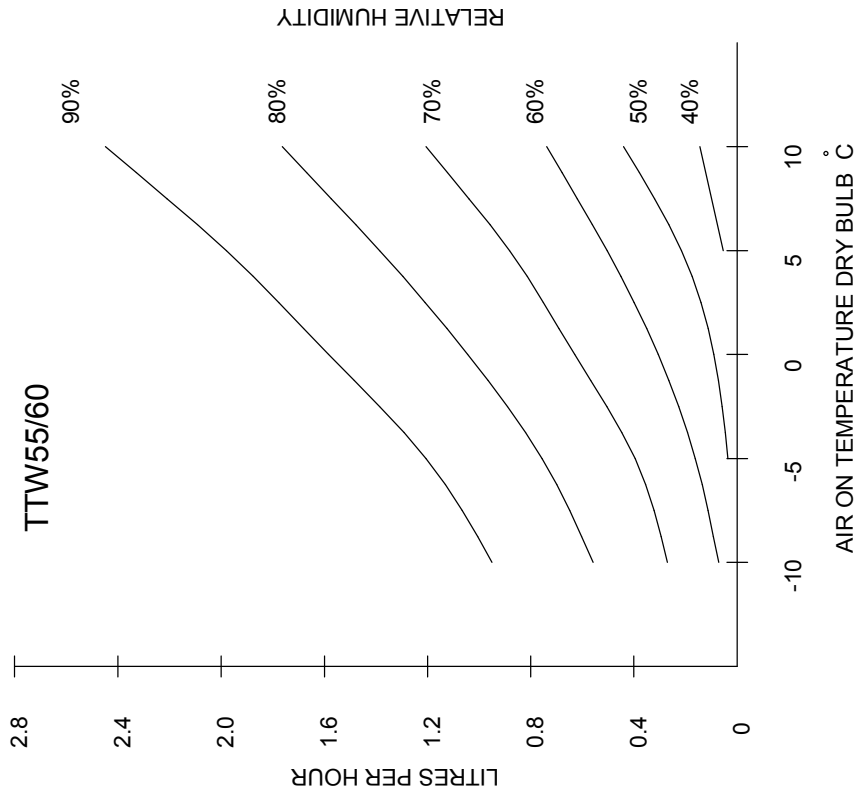

5.0 DIMENSIONS

	'A'	'B'	'C'	'D' APERTURE	'E' APERTURE	PACKED DIMENSIONS O/A
TTW30/33	875	780	560	85 x 520	110 x 520	935 L x 460 B x 900 H
TTW55/60	1300	1210	1020	85 x 980	110 x 980	1330 L x 460 B x 900 H

DUCTING & GRILLES SUPPLIED WITH MACHINE
 NOTE: EACH EXTRA DUCT SECTION WILL INCREASE THE WIDTH BY UP TO 100mm

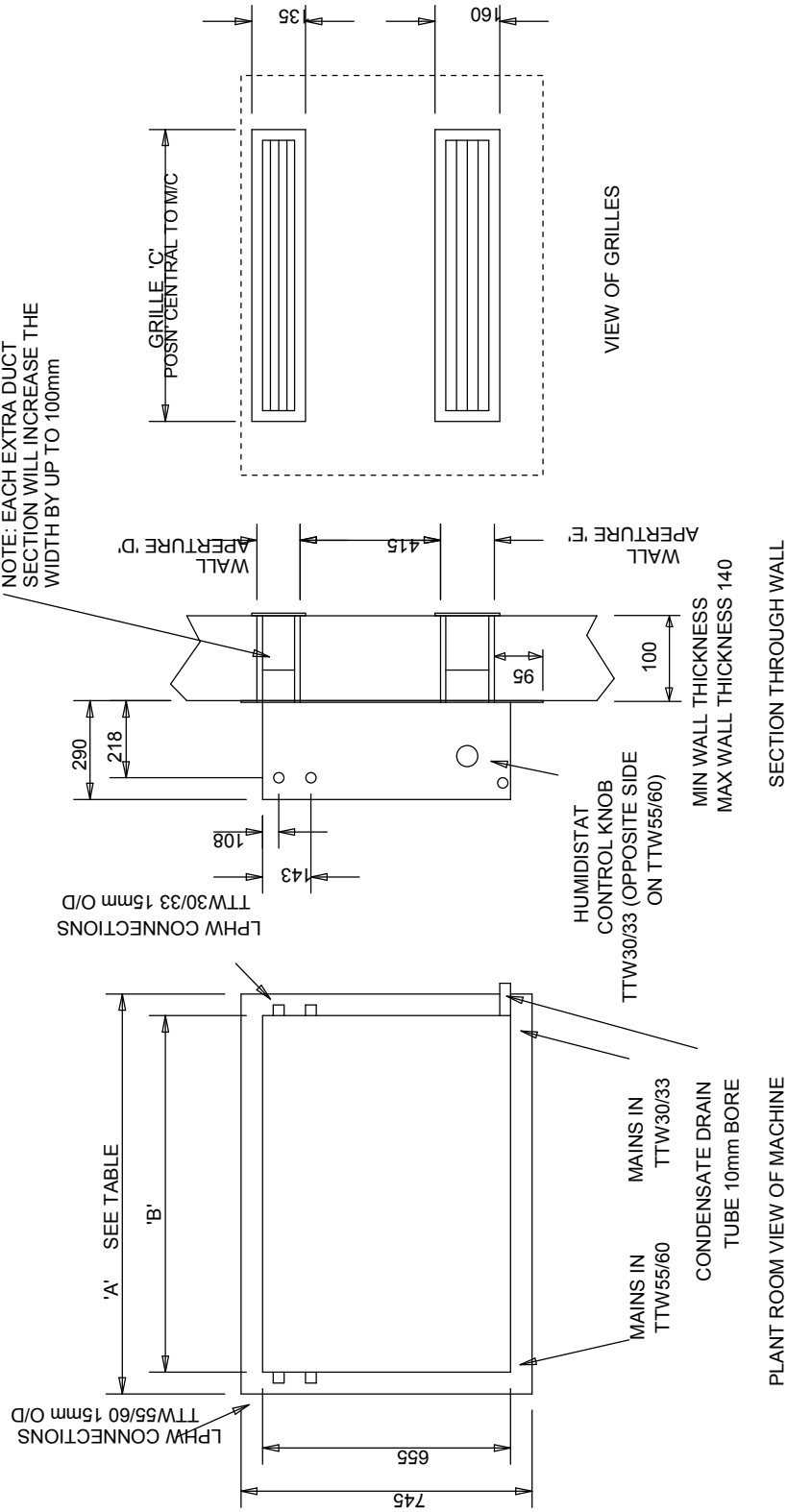

DRG No D64372650

6.0 SPARE PARTS LISTS

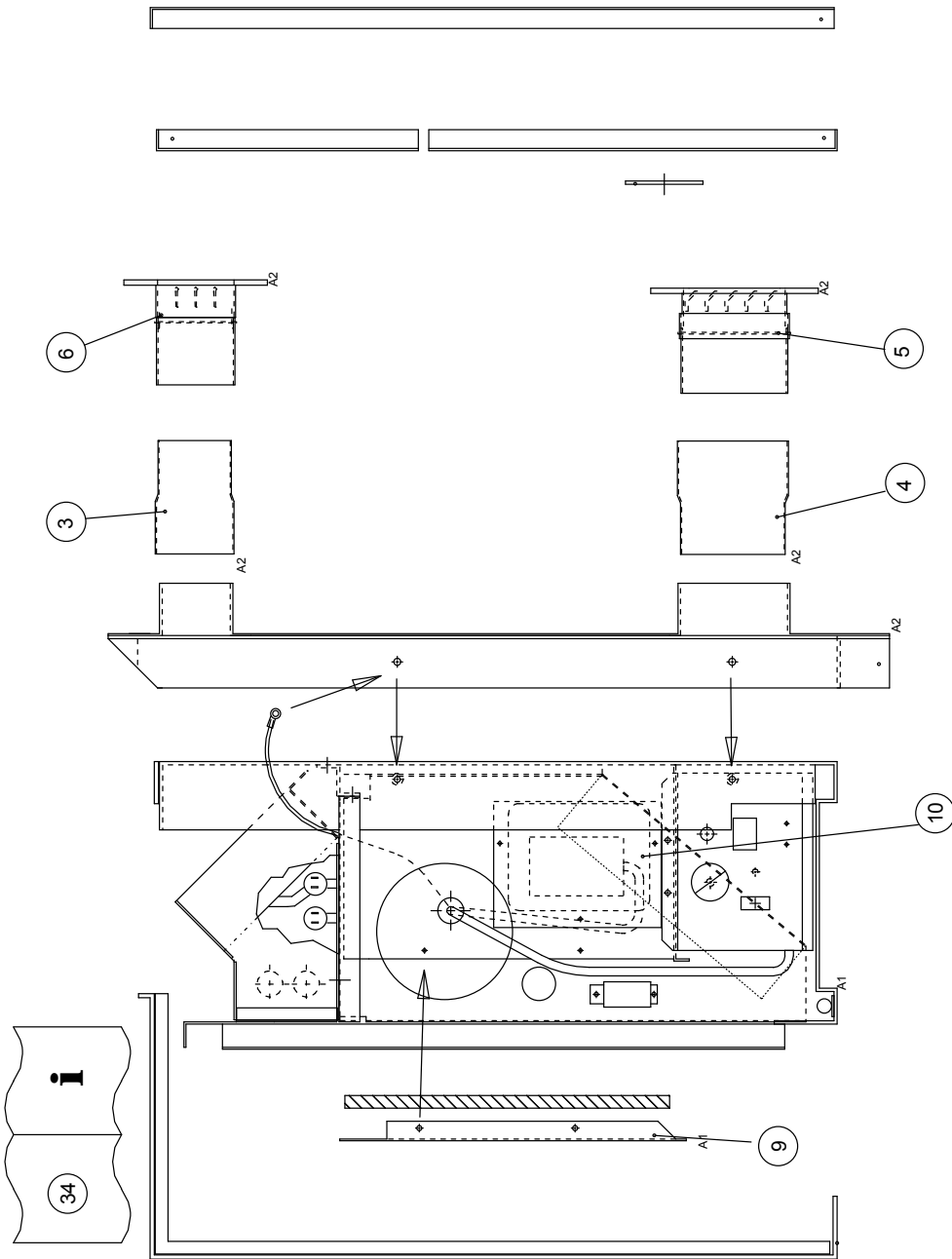

FINAL ASSY TTW30/33/30(7)/33(7) RANGE
A402001

TTW30/33/30(7)/33(7) FINAL ASSEMBLY PARTS LIST

A402001

3	SD64359750	DUCTING AIROUT	1.000
4	SD64359752	DUCTING AIR IN	1.000
5	SD64381401	GRILLE/DUCT ASSY INLET	1.000
6	SD64381402	GRILLE/DUCT ASSY OUTLET	1.000
9	SD64359950	COMPRESSOR COVER	1.000
10	SD64268150	CUTOUT COVER	1.000
34	SD64373351	INSTALLATION CARD	1.000

TTW55/55(7)/60/60(7) FINAL ASSEMBLY PARTS LIST

A402201

3	SD64359751	DUCTING AIROUT	1.000
4	SD64359753	DUCTING AIR IN	1.000
5	SD64381403	GRILLE/DUCT ASSY INLET	1.000
6	SD64381404	GRILLE/DUCT ASSY OUTLET	1.000
9	SD64359951	COMPRESSOR COVER	1.000
34	SD64373351	INSTALLATION CARD	1.000

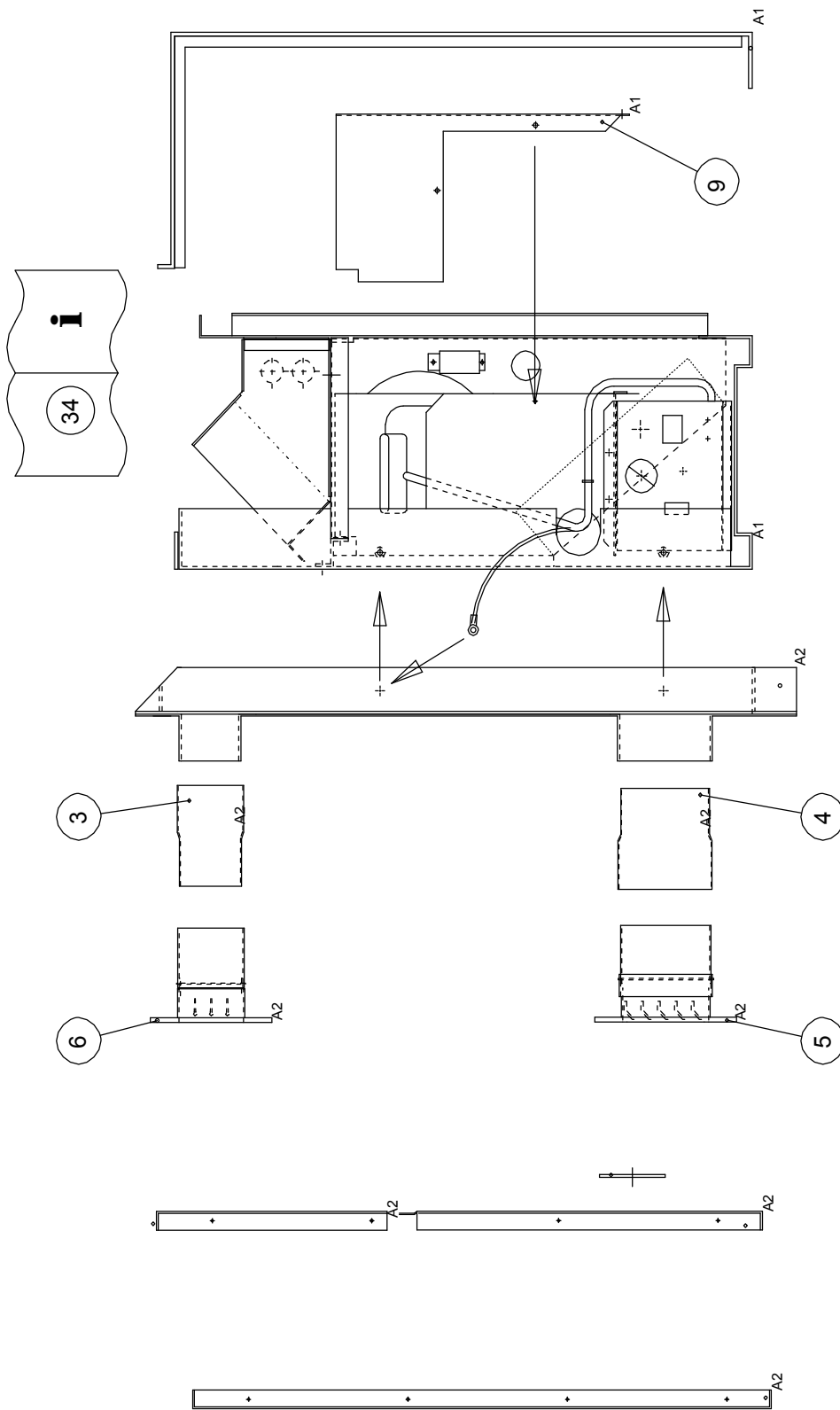

FINAL ASSY TTW55/55(7)/60/60(7) RANGE

A402201

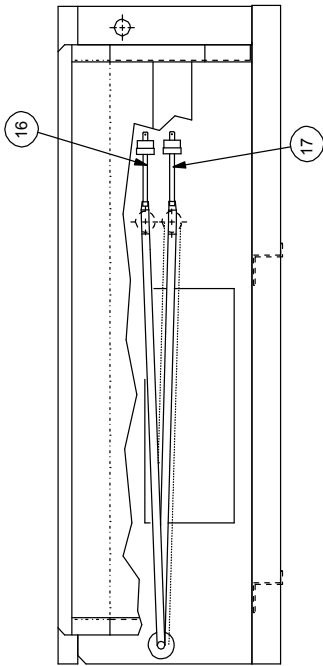

29 GAS CHARGE

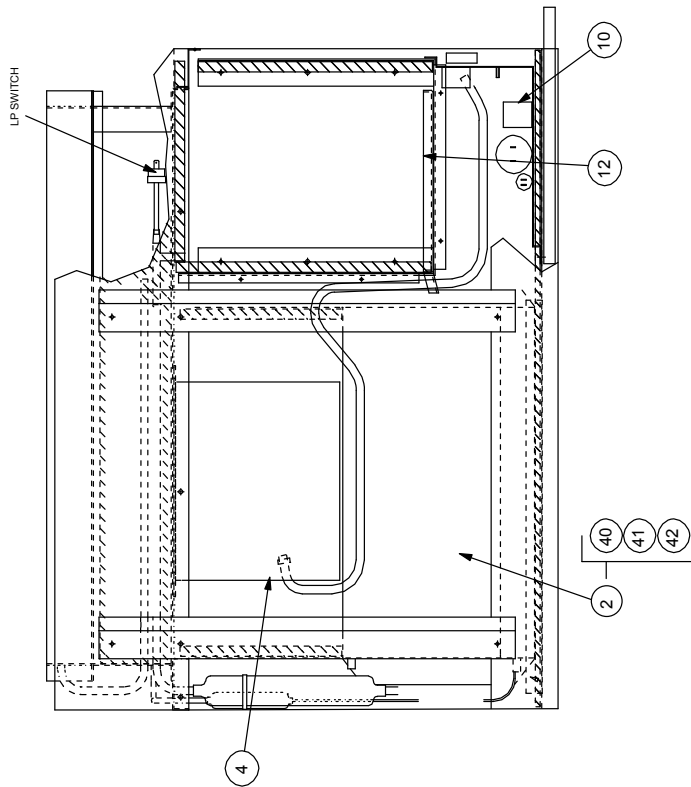
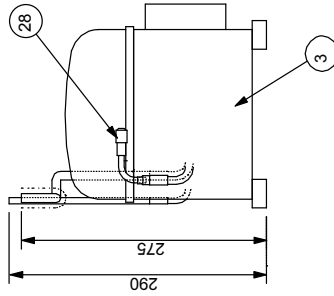
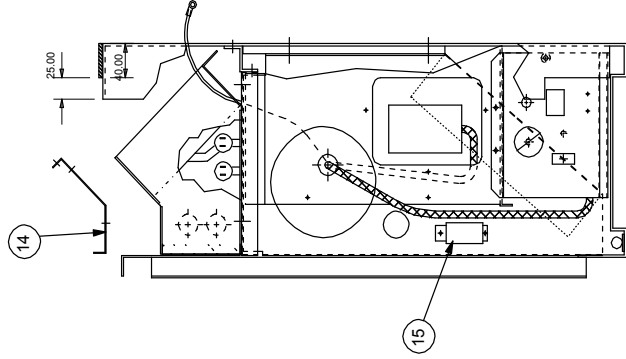

FRIDGE/ELEC ASSY TTW30/30(7)33/33(7)A
A64402101

TTW30(7)/33(7)A FRIDGE & ELEC ASSY PARTS LIST
A402101

ITEM NO.	PART No.	DESCRIPTION	QUAN
2	SD140407	EVAP/COND ASSY	1.000
3	SA144154	COMPRESSOR ASSEMBLY AE5470C	1.000
4	SD101450	FAN	1.000
10	SA374401	ELEC BOX ASSY TTW33A	1.000
12	SD146952	DRIPTRAY - COMP	1.000
14	SD264550	BLANKING PLATE	1.000
15	SD118351	DEFROST STAT CALIBRATED	1.000
16	SD266450	HP SWITCH	1.000
17	SD266550	LP SWITCH	1.000
28	SD066350	SCHRADER VALVE	1.000
29	SD182554	REFRIGERANT R407c Kg	0.500
40	SD138052	EVAPORATOR	1.000
41	SD136051	CONDENSER DH33	1.000
42	SD141250	DRIER KMP 274151	1.000

VARIATION WHEN HUMIDISTAT OPTION FITTED

AS ABOVE BUT DROP

10	SA374401	ELEC BOX ASSY TTW33A	1.000
	AND FIT		
	SA374413	ELEC BOX ASSY TTW33A + REMOTE STAT	1.000

TTW30(7)/33(7)AX FRIDGE & ELEC ASSY PARTS LIST
A402111

ITEM NO.	PART No.	DESCRIPTION	QUAN
2	SD140408	EVAP/COND ASSY	1.000
3	SA144154	COMPRESSOR ASSEMBLY AE5470C	1.000
4	SD101450	FAN	1.000
10	SA374403	ELEC BOX ASSY TTW33AX	1.000
12	SD146952	DRIPTRAY - COMP	1.000
14	SD264550	BLANKING PLATE	1.000
15	SA145803	TIMER DEFROST STAT	1.000
16	SD266450	HP SWITCH	1.000
17	SD266550	LP SWITCH	1.000
28	SD066350	SCHRADER VALVE	1.000
29	SD182554	REFRIGERANT R407c kg	0.400
40	SD138051	EVAPORATOR	1.000
41	SD136051	CONDENSER DH33	1.000
42	SD141250	DRIER KMP 274151	1.000
50	SD146150	SOLENOID VALVE	1.000
51	SD146250	SOLENOID COIL 230V	1.000

VARIATION WHEN HUMIDISTAT OPTION FITTED

AS ABOVE BUT DROP

10	SA374403	ELEC BOX ASSY TTW33AX	1.000
	AND FIT		
	SA374414	ELEC BOX ASSY TTW33AX + REMOTE STAT	1.000

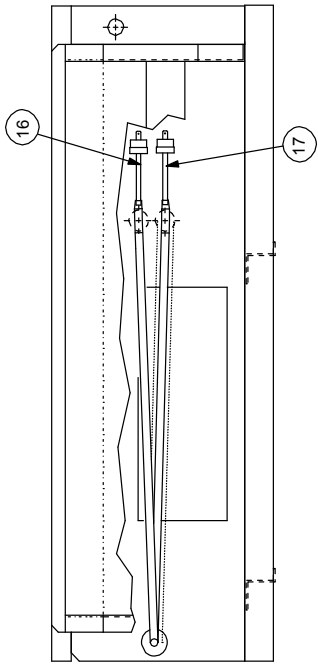

29 GAS CHARGE

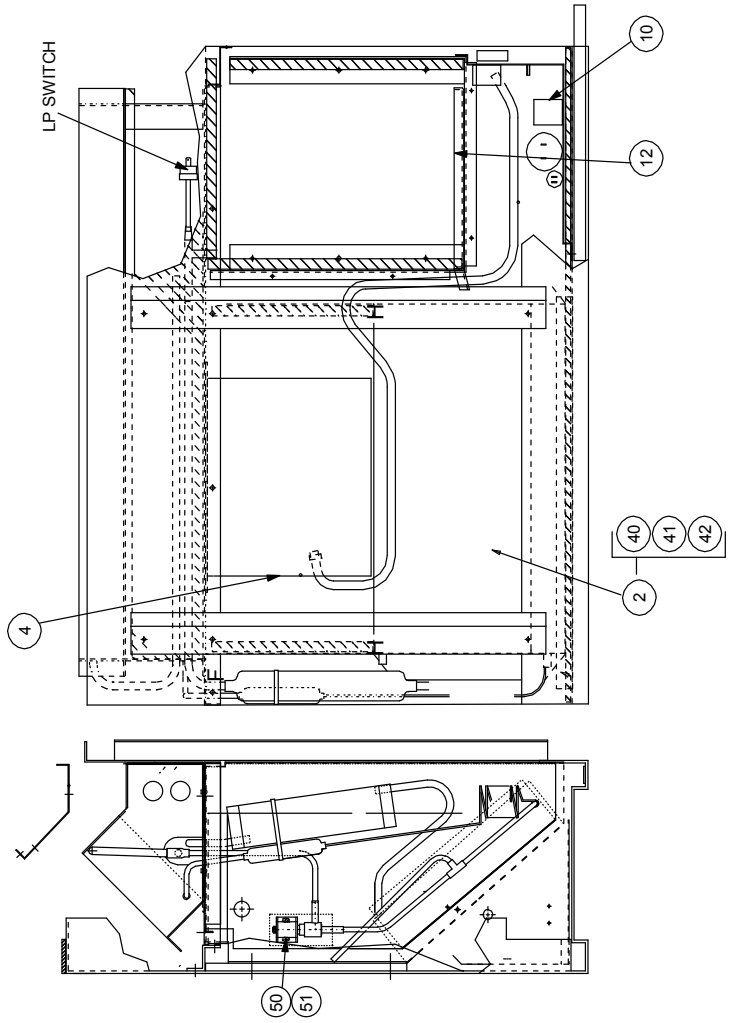
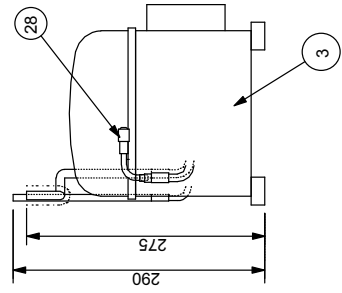
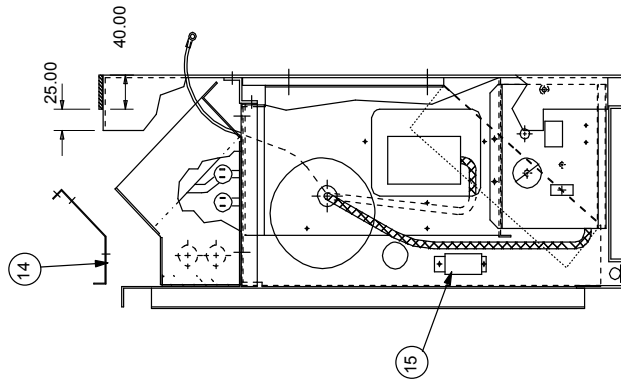

FRIDGE/ELEC ASSY TTW30/30(7)33/33(7)AX

A64402111

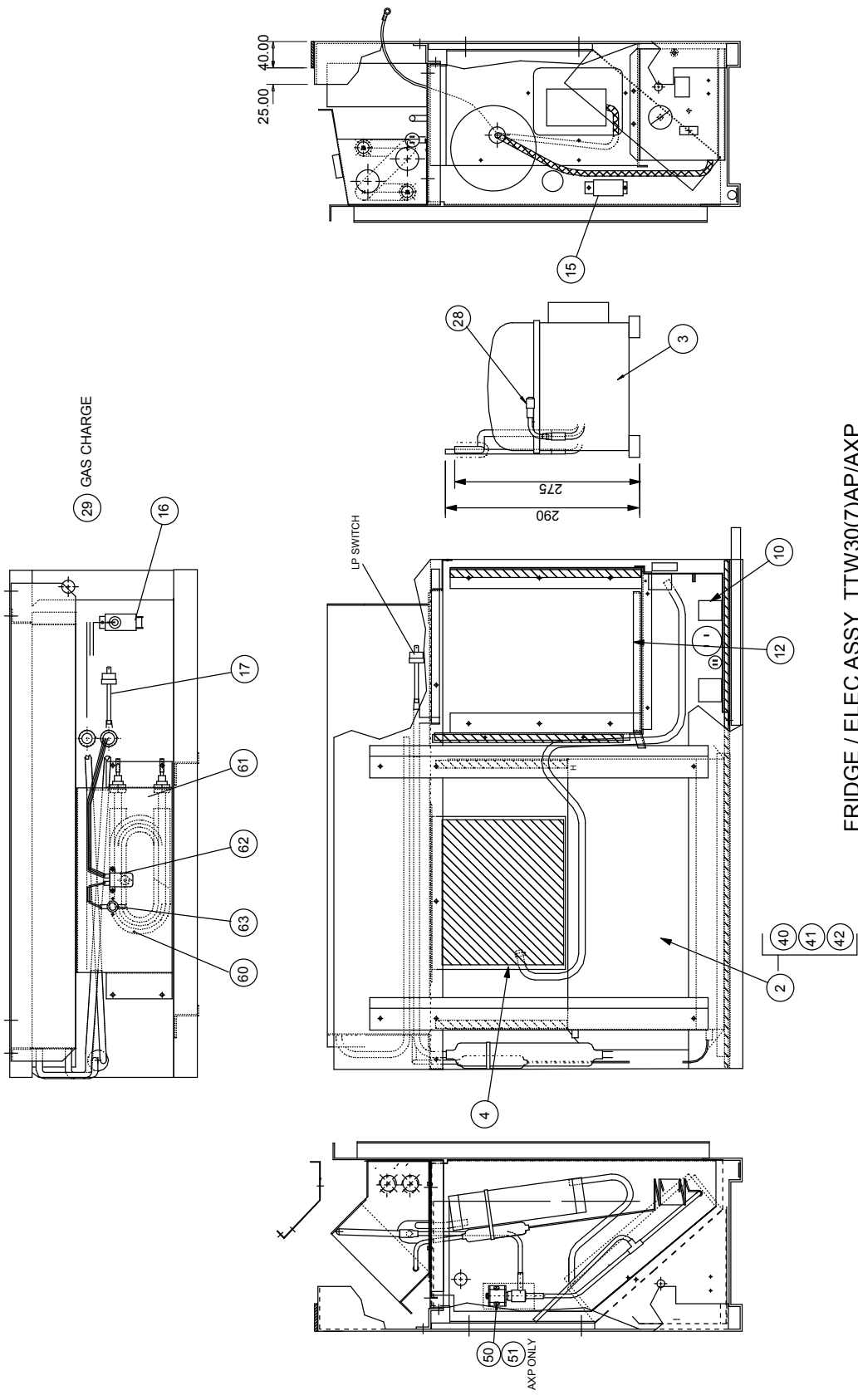

FRIDGE / ELEC ASSY TTW30(7)AP/AXP

A64402102/12

TTW30(7)AP FRIDGE & ELEC ASSY PARTS LIST
A402102

ITEM NO.	PART No.	DESCRIPTION	QUAN
2	SD140453	EVAP/COND ASSY R407c	1.000
3	SA144154	COMPRESSOR ASSEMBLY AE5470C	1.000
4	SD101450	FAN	1.000
10	SA374409	ELEC BOX ASSY	1.000
12	SD146952	DRIPTRAY - COMP	1.000
15	SD118351	DEFROST STAT CALIBRATED	1.000
16	SA062553	HP SWITCH 400 psi	1.000
17	SD266550	LP SWITCH	1.000
28	SD066350	SCHRADER VALVE	1.000
29	SD182554	REFRIGERANT R407c IN Kg	0.500
40	SD138052	EVAPORATOR	1.000
41	SD136050	CONDENSER	1.000
42	SD141250	DRIER KMP 274151	1.000
60	SD362850	AIR HEATER ELEMENT	1.000
61	SD362950	HEATER COVER	1.000
62	SD103251	THERMAL CUTOUT AUTO RESET	1.000
63	SD103254	THERMAL CUTOUT MANUAL RESET 115C	1.000

TTW30(7)AXP FRIDGE & ELEC ASSY PARTS LIST
A64402112

ITEM NO.	PART No.	DESCRIPTION	QUAN
2	SD140454	EVAP/COND ASSY R407c	1.000
3	SA144154	COMPRESSOR ASSEMBLY AE5470C	1.000
4	SD101450	FAN	1.000
10	SA374411	ELEC BOX ASSY	1.000
12	SD146952	DRIPTRAY - COMP	1.000
15	SA145803	DEFROST STAT CALIBRATED	1.000
16	SA062553	HP SWITCH 400 psi	1.000
17	SD266550	LP SWITCH	1.000
28	SD066350	SCHRADER VALVE	1.000
29	SD182554	REFRIGERANT R407c IN kg	0.450
40	SD138051	EVAPORATOR	1.000
41	SD136050	CONDENSER	1.000
42	SD141250	DRIER KMP 274151	1.000
50	SD146150	SOLENOID VALVE	1.000
51	SD146250	SOLENOID COIL 230V	1.000
60	SD362850	AIR HEATER ELEMENT	1.000
61	SD362950	HEATER COVER	1.000
62	SD103251	THERMAL CUTOUT AUTO RESET	1.000
63	SD103254	THERMAL CUTOUT MANUAL RESET 115C	1.000

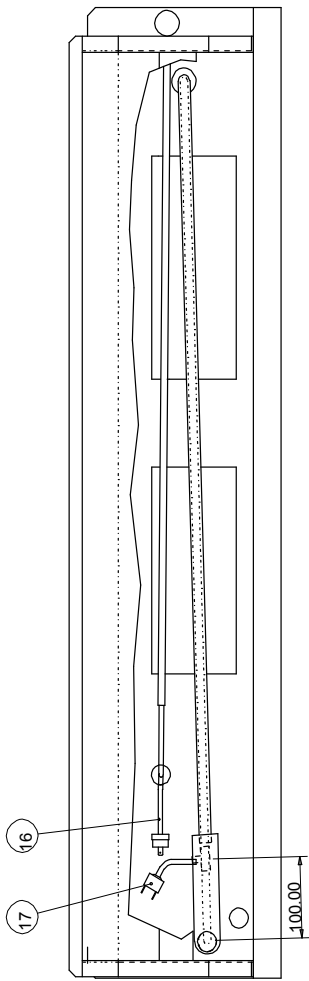

28 GAS CHARGE

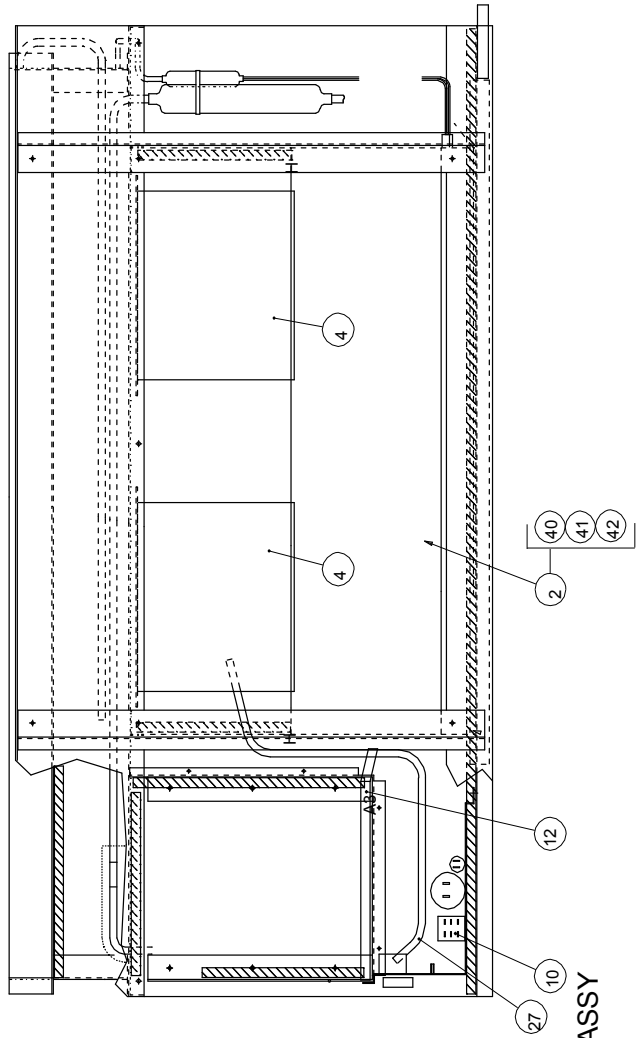
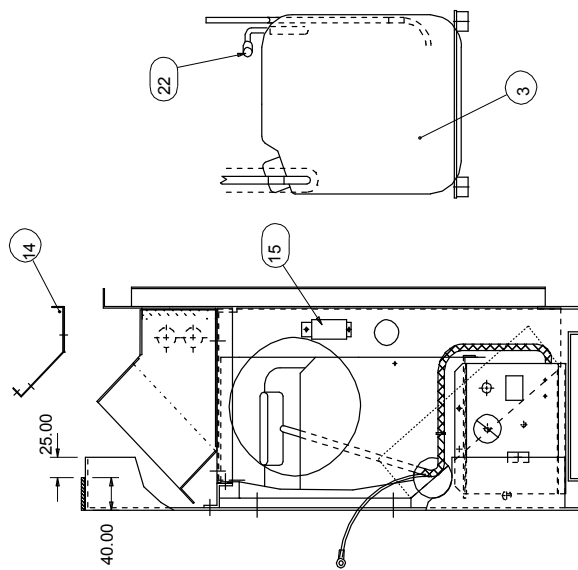

TTW55/55(7)/60/60(7)A FRIDGE & ELEC ASSY

A64402301

TTW55(7)/60(7)A FRIDGE & ELEC ASSY PARTS LIST

A402301

ITEM NO.	PART No.	DESCRIPTION	QUAN
2	SD140707	EVAP/CONDENSER ASSY	1.000
3	SD132652	COMP ASPERA J7225GE 132653	1.000
4	SD101450	FAN	2.000
10	SA374402	ELEC BOX ASSY TTW55A	1.000
12	SD146851	COMP DRIPTRAY	1.000
14	SD264551	BLANKING PLATE DH50	1.000
15	SD118351	DEFROST STAT CALIBRATED	1.000
16	SD266450	HP SWITCH	1.000
17	SD266550	LP SWITCH	1.000
22	SD066350	SCHRADER VALVE	1.000
28	SD182554	REFRIGERANT R407c IN Kg	0.750
40	SD139152	EVAPORATOR	1.000
41	SD137851	CONDENSER	1.000
42	SD141250	DRIER KMP 274151	1.000

VARIATION WHEN HUMIDISTAT OPTION FITTED

AS ABOVE BUT DROP

10	SA374402	ELEC BOX ASSY TTW55A	1.000
		AND FIT	
	SA374415	ELEC BOX ASSY TTW55A + REMOTE STAT	1.000

TTW55(7)/60(7)AX FRIDGE & ELEC ASSY PARTS LIST

A402311

ITEM NO.	PART No.	DESCRIPTION	QUAN
2	SD140708	EVAP/CONDENSER ASSY	1.000
3	SD132652	COMP ASPERA J7225GE 132653	1.000
4	SD101450	FAN	2.000
10	SA374404	ELEC BOX ASSY TTW55AX	1.000
12	SD146851	COMP DRIPTRAY	1.000
14	SD264551	BLANKING PLATE DH50	1.000
15	SA145803	TIMER DEFROST STAT	1.000
16	SD266450	HP SWITCH	1.000
17	SD266550	LP SWITCH	1.000
22	SD066350	SCHRADER VALVE	1.000
28	SD182554	REFRIGERANT R407c IN Kg	0.800
40	SD139151	EVAPORATOR	1.000
41	SD137851	CONDENSER DH55AX	1.000
42	SD141250	DRIER KMP 274151	1.000
50	SD146150	SOLENOID VALVE	1.000
51	SD146259	SOLENOID COIL 230V	1.000

VARIATION WHEN HUMIDISTAT OPTION FITTED

AS ABOVE BUT DROP

10	SA374404	ELEC BOX ASSY TTW55AX	1.000
		AND FIT	
	SA374416	ELEC BOX ASSY TTW55AX + REMOTE STAT	1.000

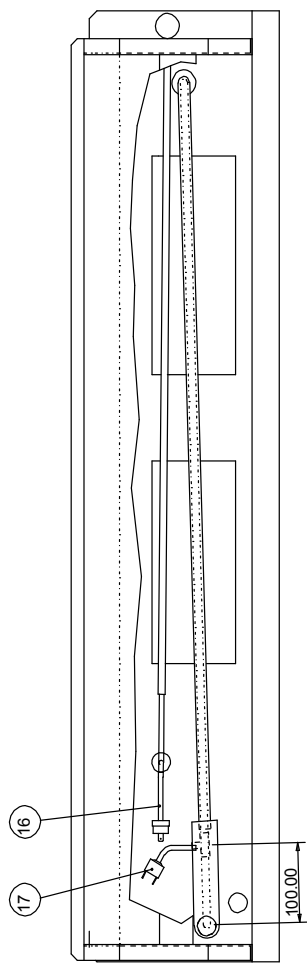

28) GAS CHARGE

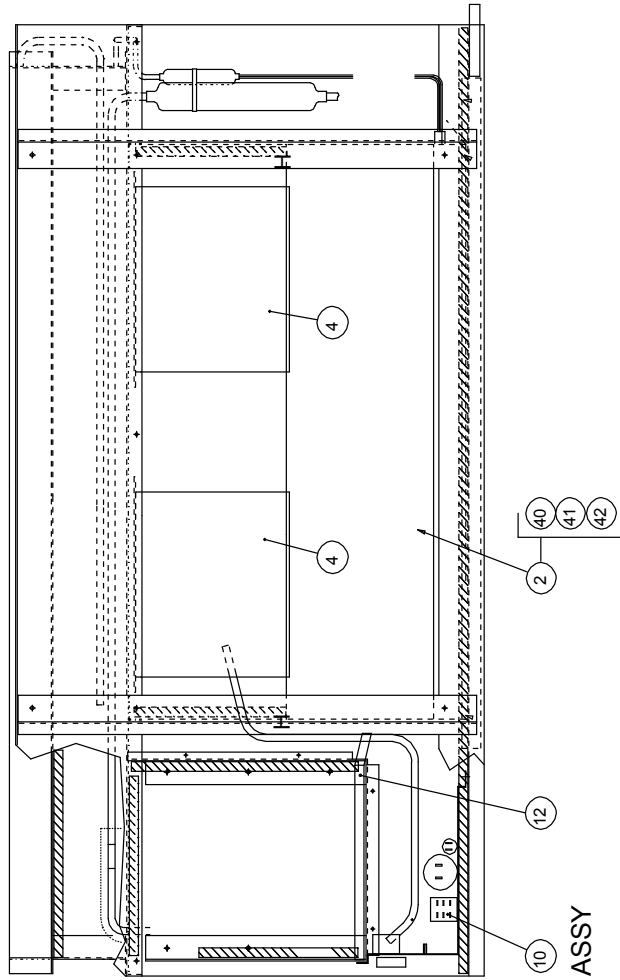
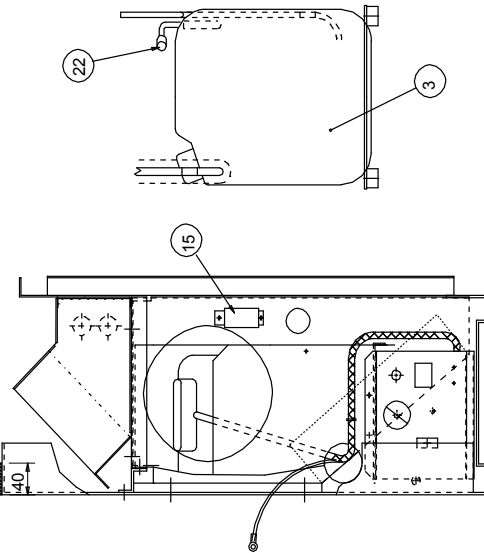
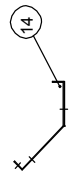
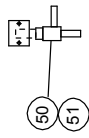

TTW55/55(7)/60/60(7)AX FRIDGE & ELEC ASSY

A64402311

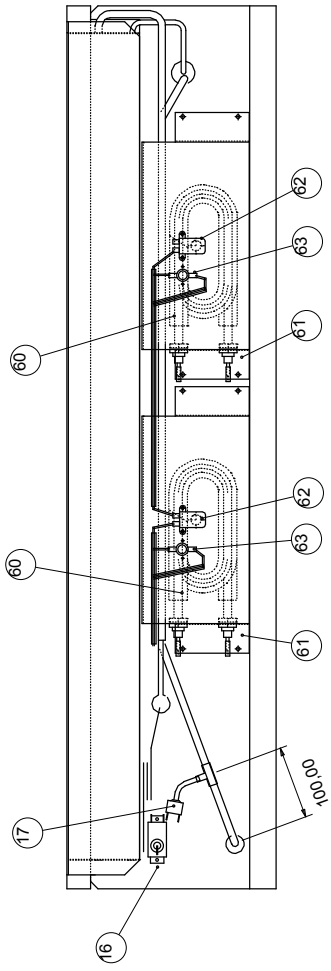

TTW 50 AXP ONLY

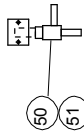

28 GAS CHARGE

LP SWITCH

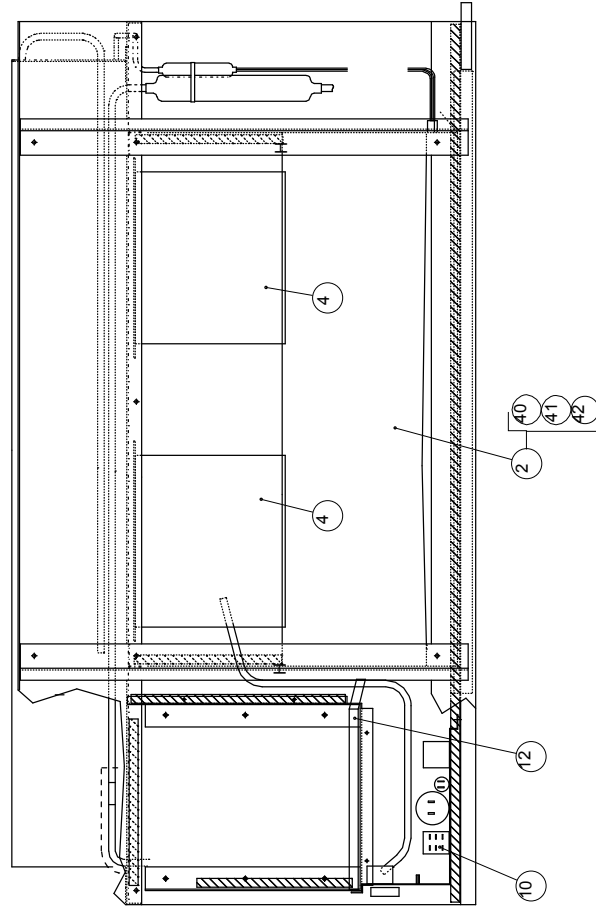
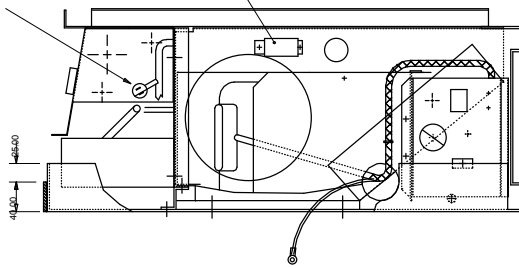
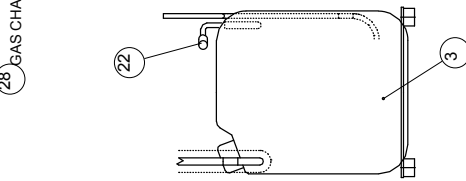

FRIDGE / ELEC ASSY TTW50(7)AP / AXP

A64402302/12

TTW50(7)AP FRIDGE & ELEC ASSY PARTS LIST
A402302

2	SD140753	EVAP/CONDENSER ASSY	1.000
3	SD132652	COMPRESSOR J7225GE ASPERA	132653 1.000
4	SD101450	FAN	2.000
10	SA374410	ELEC BOX ASSY	1.000
12	SD146851	COMP DRIPTRAY	1.000
15	SD118351	DEFROST STAT CALIBRATED	1.000
16	SA062553	HP SWITCH 400 psi	1.000
17	SD266550	LP SWITCH	1.000
22	SD066350	SCHRADER VALVE	1.000
28	SD182554	REFRIGERANT R407c IN Kg	0.750
40	SD139152	EVAPORATOR	1.000
41	SD137850	CONDENSER	1.000
42	SD141250	DRIER KMP 274151	1.000
60	SD362850	AIR HEATER ELEMENT	2.000
61	SD362950	HEATER COVER	2.000
62	SD103251	THERMAL CUTOUT AUTO RESET	2.000
63	SD103254	THERMAL CUTOUT MANUAL RESET 115C	2.000

TTW50(7)AXP FRIDGE & ELEC ASSY PARTS LIST
A402312

2	SD140754	EVAP/CONDENSER ASSY	1.000
3	SD132652	COMPRESSOR J7225GE ASPERA	132653 1.000
4	SD101450	FAN	2.000
10	SA374412	ELEC BOX ASSY	1.000
12	SD146851	COMP DRIPTRAY	1.000
15	SA145803	TIMER DEFROST STAT	1.000
16	SA062553	HP SWITCH 400 psi	1.000
17	SD266550	LP SWITCH	1.000
22	SD066350	SCHRADER VALVE	1.000
28	SD182554	REFRIGERANT R407c IN Kg	0.800
40	SD139151	EVAPORATOR	1.000
41	SD137850	CONDENSER	1.000
42	SD141250	DRIER KMP 274151	1.000
50	SD146250	SOLENOID VALVE COIL 240v	1.000
51	SD146150	SOLENOID VALVE	1.000
60	SD362850	AIR HEATER ELEMENT	2.000
61	SD362950	HEATER COVER	2.000
62	SD103251	THERMAL CUTOUT AUTO RESET	2.000
63	SD103254	THERMAL CUTOUT MANUAL RESET 115C	2.000

ELEC BOX ASSY TTW30/30(7)/33/33(7)A
SA374401

2	SD154650	RELAY 2 POLE 20A 230V AC COIL	1.000
3	SD038750	RUN CAP 15 μ F 370V	1.000
4	SD106550	FAN CAP 2 μ F 440V	1.000
5	SD089550	9 MIN TIMER	1.000
6	SD188950	ROCKER SWITCH 1 POLE C/O	1.000
7	SA062301	HUMIDISTAT	1.000
8	SD041450	CONTROL KNOB	1.000
10	SD072851	16A 3WAY TERMINAL BLOCK	1.000
14	SA372801	LOOM ASSY	1.000
15	SD028750	CABLE CLAMP	2.000
17	SD144250	U TYPE NUT	1.000

ELEC BOX ASSY TTW30/30(7)/33/33(7)AX
SA374403

2	SD154650	RELAY 2 POLE 20A 230V AC COIL	1.000
3	SD038750	RUN CAP 15 μ F 370V	1.000
4	SD106550	FAN CAP 2 μ F 440V	1.000
5	SD089550	9 MIN TIMER	1.000
6	SD188950	ROCKER SWITCH 1 POLE C/O	1.000
7	SA062301	HUMIDISTAT	1.000
8	SD041450	CONTROL KNOB	1.000
10	SD072851	16A 3WAY TERMINAL BLOCK	1.000
14	SA372803	LOOM ASSY	1.000
15	SD028750	CABLE CLAMP	2.000
17	SD144250	U TYPE NUT	1.000

ELEC BOX ASSY TTW30/30(7)/33/33(7)A/AX

SA374401/03

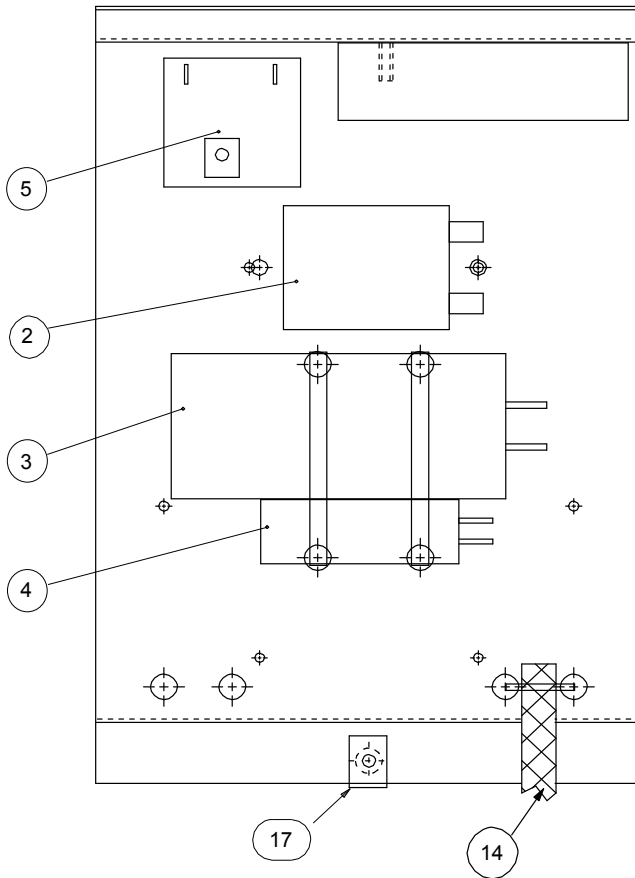
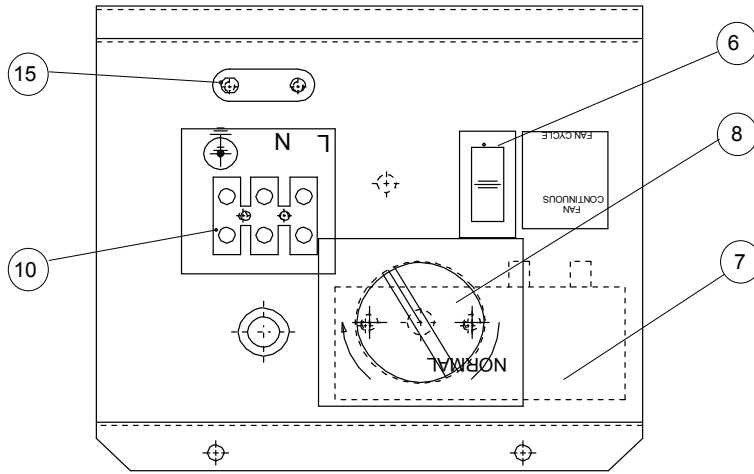

ELEC BOX ASSY TTW55/55(7)/60/60(7)A/AX

SA374402/04

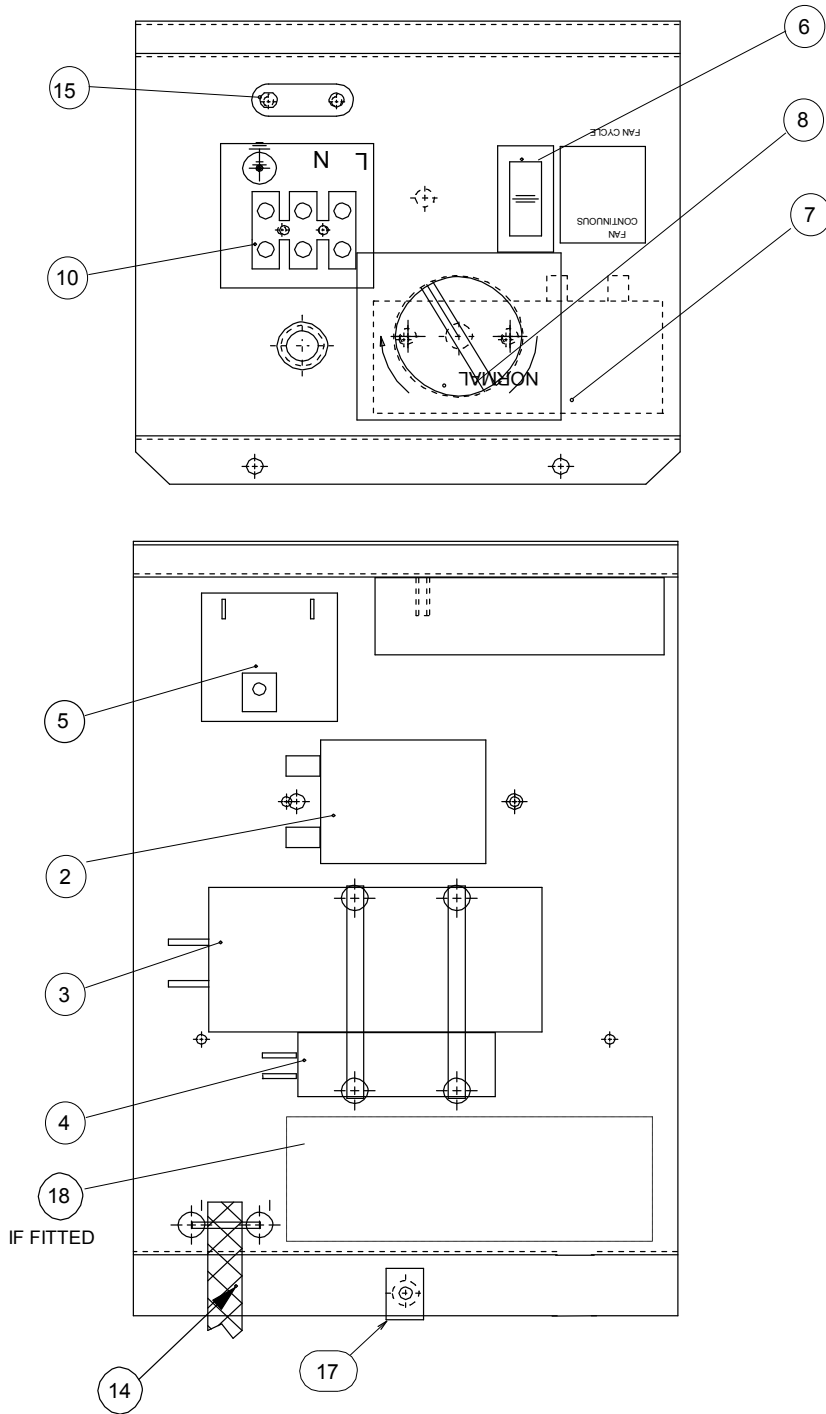

ELEC BOX ASSY TTW55/55(7)/60/60(7)A
SA374402

2	SD092151	RELAY 1 POLE N/O 208/230V 50/60Hz	1.000
3	SD038750	RUN CAP 15 μ F 400V	1.000
4	SD106550	FAN CAP 2 μ F 440V	2.000
5	SD089550	9 MIN TIMER	1.000
6	SD188950	ROCKER SWITCH 1 POLE C/O	1.000
7	SA062301	HUMIDISTAT	1.000
8	SD041450	CONTROL KNOB	1.000
10	SD072851	16A 3WAY TERMINAL BLOCK	1.000
15	SD028750	CABLE CLAMP	2.000
17	SD144250	U TYPE NUT	1.000

ELEC BOX ASSY TTW55/55(7)/60/60(7)AX
SA374404

2	SD092151	RELAY 1 POLE N/O 208/230V 50/60Hz	1.000
3	SD038750	RUN CAP 15 μ 400F	1.000
4	SD106550	FAN CAP 2 μ F 440V	2.000
5	SD089550	9 MIN TIMER	1.000
6	SD188950	ROCKER SWITCH 1 POLE C/O	1.000
7	SA062301	HUMIDISTAT	1.000
8	SD041450	CONTROL KNOB	1.000
10	SD072851	16A 3WAY TERMINAL BLOCK	1.000
15	SD028750	CABLE CLAMP	2.000
17	SD144250	U TYPE NUT	1.000

ELEC BOX ASSY TTW30(7)/50(7)AP/XP
 SA374409/10/11/12

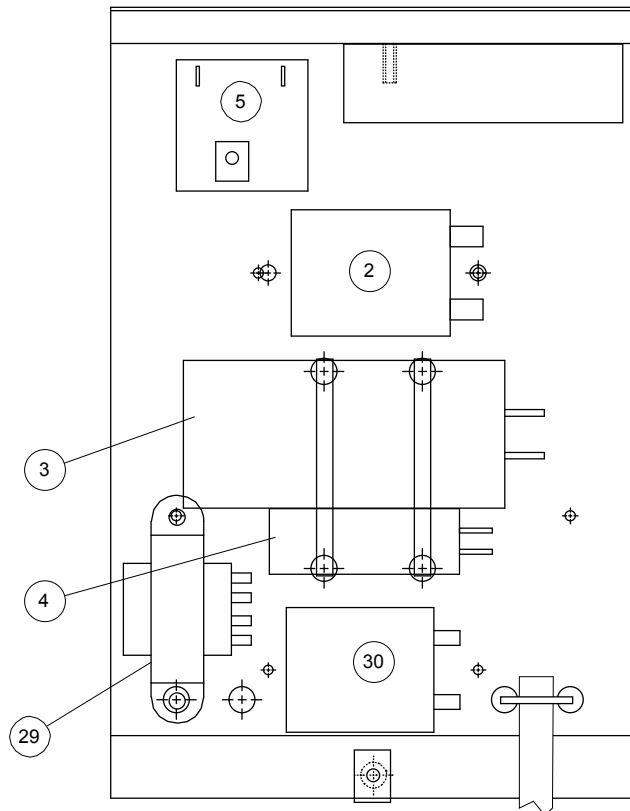
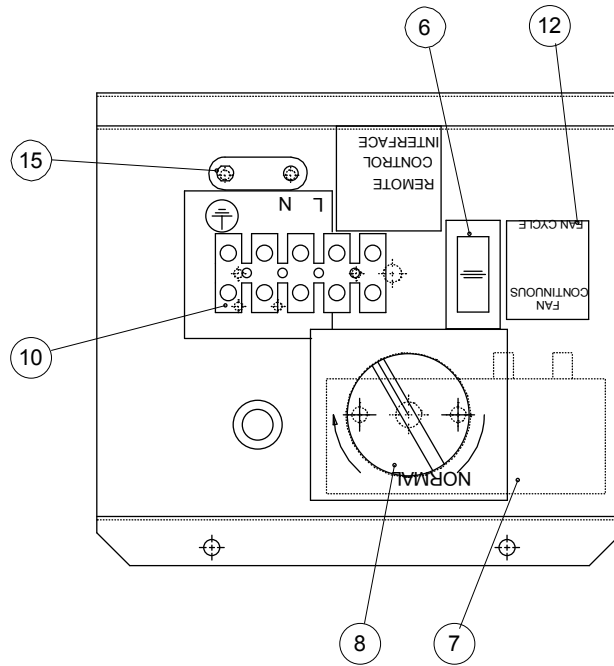

ELEC BOX ASSY TTW30(7)AP

SA374409

2	SD154650	RELAY C/O 2 POLE 20A 230V AC COIL	1.000
3	SD038750	RUN CAP 15 μ F 400V	1.000
4	SD106550	FAN CAP 2 μ F 440V	1.000
5	SD089550	9 MIN TIMER	1.000
6	SD188950	ROCKER SWITCH 1 POLE C/O	1.000
7	SA062301	HUMIDISTAT	1.000
8	SD041450	CONTROL KNOB	1.000
10	SD072853	15A 5 WAY TERMINAL BLOCK	1.000
12	SD189050	LABEL ROCKER SWITCH	1.000
13	SA372805	LOOM ASSY	1.000
15	SD028750	CABLE CLAMP	2.000
27	SD147450	DOUBLE SIDED PAD	1.000
29	SD336550	TRANSFORMER 0-12 (12V)	1.000
30	SD378350	RELAY 25A C/O 12V COIL	1.000

WIRING DIAGRAM FOR THIS MACHINE IS D372754

ELEC BOX ASSY TTW50(7)AP

SA374410

2	SD092151	RELAY 1 POLE N/O 230V 50/60Hz	1.000
3	SD038750	RUN CAP 15 μ F 400V	1.000
4	SD106550	FAN CAP 2 μ F 440V	2.000
5	SD089550	9 MIN TIMER	1.000
6	SD188950	ROCKER SWITCH 1 POLE C/O	1.000
7	SA062301	HUMIDISTAT	1.000
8	SD041450	CONTROL KNOB	1.000
10	SD072650	TERMINAL BLOCK	1.000
12	SD189050	LABEL ROCKER SWITCH	1.000
13	SA372806	LOOM ASSY	1.000
15	SD028750	CABLE CLAMP	2.000
27	SD147450	DOUBLE SIDED PAD	1.000
29	SD336550	TRANSFORMER 0-12 (12V)	1.000
30	SD378350	RELAY 25A C/O 12V COIL	1.000

WIRING DIAGRAM FOR THIS MACHINE IS D372754

ELEC BOX ASSY TTW30(7)AXP
SA374411

2	SD154650	RELAY C/O 2 POLE 20A 230V AC COIL	1.000
3	SD038750	RUN CAP 15 μ F 400V	1.000
4	SD106550	FAN CAP 2 μ F 440V	1.000
5	SD089550	9 MIN TIMER	1.000
6	SD188950	ROCKER SWITCH 1 POLE C/O	1.000
7	SA062301	HUMIDISTAT	1.000
8	SD041450	CONTROL KNOB	1.000
10	SD072853	15A 5 WAY TERMINAL BLOCK	1.000
12	SD189050	LABEL ROCKER SWITCH	1.000
13	SD372807	LOOM ASSY	1.000
15	SD028750	CABLE CLAMP	2.000
27	SD147450	DOUBLE SIDED PAD	1.000
29	SD336550	TRANSFORMER 0-12 (12V)	1.000
30	SD378350	RELAY 25A C/O 12V COIL	1.000

WIRING DIAGRAM FOR THIS MACHINE IS D372755

ELEC BOX ASSY TTW50(7)AXP
SA374412

2	SD092151	RELAY 1 POLE N/O 230V 50/60Hz	1.000
3	SD038750	RUN CAP 15 μ F 400V	1.000
4	SD106550	FAN CAP 2 μ F 440V	2.000
5	SD089550	9 MIN TIMER	1.000
6	SD188950	ROCKER SWITCH 1 POLE C/O	1.000
7	SA062301	HUMIDISTAT	1.000
8	SD041450	CONTROL KNOB	1.000
10	SD072650	TERMINAL BLOCK	1.000
12	SD189050	LABEL ROCKER SWITCH	1.000
13	SA372808	LOOM ASSY	1.000
15	SD028750	CABLE CLAMP	2.000
27	SD147450	DOUBLE SIDED PAD	1.000
29	SD336550	TRANSFORMER 0-12 (12V)	1.000
30	SD378350	RELAY 25A C/O 12V COIL	1.000

WIRING DIAGRAM FOR THIS MACHINE IS D372755

ELEC BOX ASSY TTW30/33A/AX WITH REMOTE HUMIDISTAT
SA374413/14

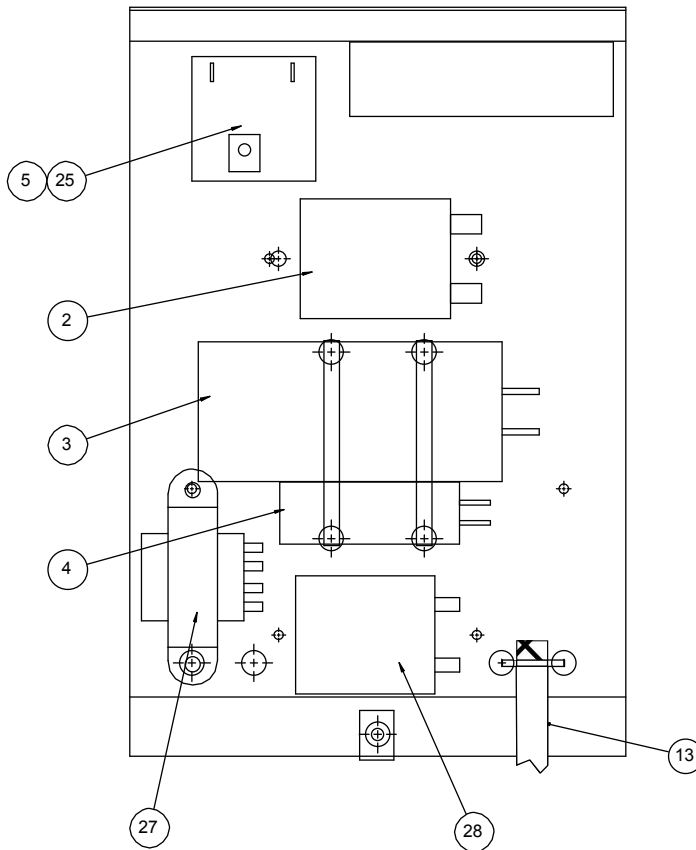
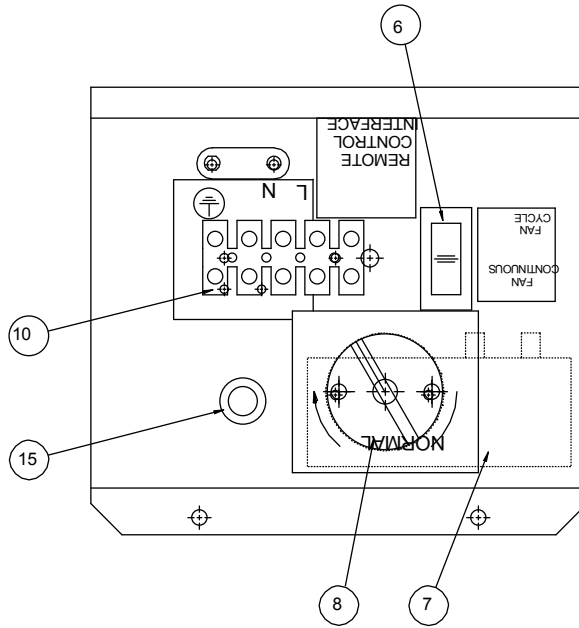

ASSEMBLY PART No	USED ON	WIRING DIAGRAM
SA374413	TTW30/33A WITH REMOTE STAT	D372752
SA374414	TTW30/33AX WITH REMOTE STAT	D372753

ELEC BOX ASSY TTW30/33A + REM HUMIDISTAT

SA374413

ITEM NO.	PART No.	DESCRIPTION	QUAN
2	SD154650	RELAY C/O 2 POLE 20A 230V AC COIL	1.000
3	SD038750	CAPACITOR RUN CAP 15 μ F+/-5% 400V	1.000
4	SD106550	CAPACITOR 2 μ F 440V	1.000
5	SD089550	DELAY TIMER 7 SEC TO 9 MIN	1.000
6	SD188950	ROCKER SWITCH 1 POLE C/O	1.000
7	SA062301	HUMIDISTAT	1.000
8	SD041450	CONTROL KNOB	1.000
10	SA072853	5 WAY TERMINAL BLOCK	1.000
13	SA372809	LOOM ASSY	1.000
25	SP147450	DOUBLE SIDED ADHESIVE PAD 25mm	1.000
27	SD336550	TRANSFORMER 12V 6VA	1.000
28	SD378350	RELAY 25V C/O 12V COIL	1.000

ELEC BOX ASSY TTW30/33AX + REM HUMIDISTAT

SA374414

ITEM NO.	PART No.	DESCRIPTION	QUAN
2	SD219250	RELAY C/O 2 POLE 25A 230V AC COIL	1.000
3	SD038750	CAPACITOR RUN CAP 15 μ F+/-5% 400V	1.000
4	SD106550	CAPACITOR 2 μ F 440V	1.000
5	SD089550	DELAY TIMER 7 SEC TO 9 MIN	1.000
6	SD188950	ROCKER SWITCH 1 POLE C/O	1.000
7	SA062301	HUMIDISTAT	1.000
8	SD041450	CONTROL KNOB	1.000
10	SA072853	5 WAY TERMINAL BLOCK	1.000
13	SA372810	LOOM ASSY	1.000
25	SP147450	DOUBLE SIDED ADHESIVE PAD 25mm	1.000
27	SD336550	TRANSFORMER 12V 6VA	1.000
28	SD378350	RELAY 25V C/O 12V COIL	1.000

ELEC BOX ASSY TTW55/60A/AX WITH REMOTE HUMIDISTAT
SA374415/16

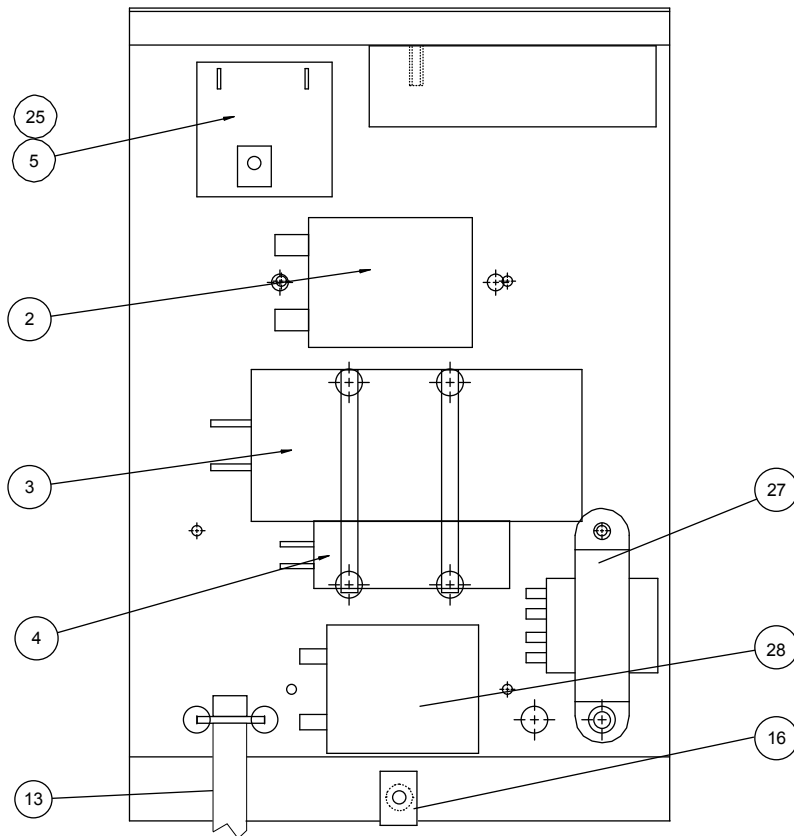
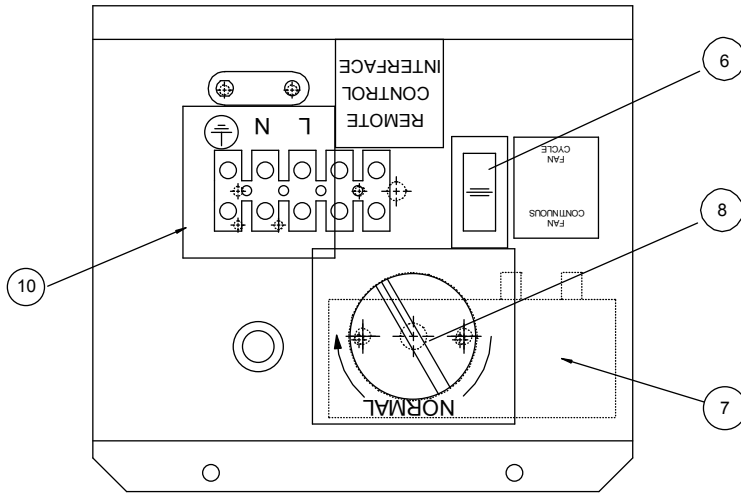

ASSEMBLY PART No	USED ON	WIRING DIAGRAM
SA374415	TTW55/60A WITH REMOTE STAT	D372752
SA374416	TTW55/60AX WITH REMOTE STAT	D372753

ELEC BOX ASSY TTW55/60A + REM HUMIDISTAT

SA374415

ITEM NO.	PART No.	DESCRIPTION	QUAN
2	SD092151	RELAY N/O 1POLE 30A 230vac COIL	1
3	SD038750	CAPACITOR RUN CAP 15 μ F+/-5% 400V	1
4	SD106550	CAPACITOR 2 μ F 440V	2
5	SD089550	DELAY TIMER 7 SEC TO 9 MIN	1
6	SD188950	ROCKER SWITCH 1 POLE C/O	1
7	SA062301	HUMIDISTAT	1
8	SD041450	CONTROL KNOB	1
10	SD072853	TERMINAL BLOCK 5 WAY	1
12	SD189050	LABEL ROCKER SWITCH	1
13	SA372811	LOOM ASSY	1
25	SP147450	DOUBLE SIDED ADHESIVE PAD 25mm	1
27	SD336550	TRANSFORMER 12V 6VA	1
28	SD378350	RELAY 25V C/O 12V COIL	1

ELEC BOX ASSY TTW55/60AX + REM HUMIDISTAT

SA374416

ITEM NO.	PART No.	DESCRIPTION	QUAN
2	SD092151	RELAY N/O 1POLE 30A 230vac COIL	1
3	SD038750	CAPACITOR RUN CAP 15 μ F+/-5% 400V	1
4	SD106550	CAPACITOR 2 μ F 440V	2
5	SD089550	DELAY TIMER 7 SEC TO 9 MIN	1
6	SD188950	ROCKER SWITCH 1 POLE C/O	1
7	SA062301	HUMIDISTAT	1
8	SD041450	CONTROL KNOB	1
10	SD072853	TERMINAL BLOCK 5 WAY	1
12	SD189050	LABEL ROCKER SWITCH	1
13	SA372812	TTW55/60AX LOOM ASSEMBLY	1
25	SP147450	DOUBLE SIDED ADHESIVE PAD 25mm	1
27	SD336550	TRANSFORMER 12V 6VA	1
28	SD378350	RELAY 25V C/O 12V COIL	1

7.0 OPTIONAL KITS

7.1 12V REMOTE HUMIDISTAT KIT

NOTES

1. SEE WIRING DIAGRAMS FOR CONNECTION & ALTERATIONS TO ELEC BOX ASSY'S

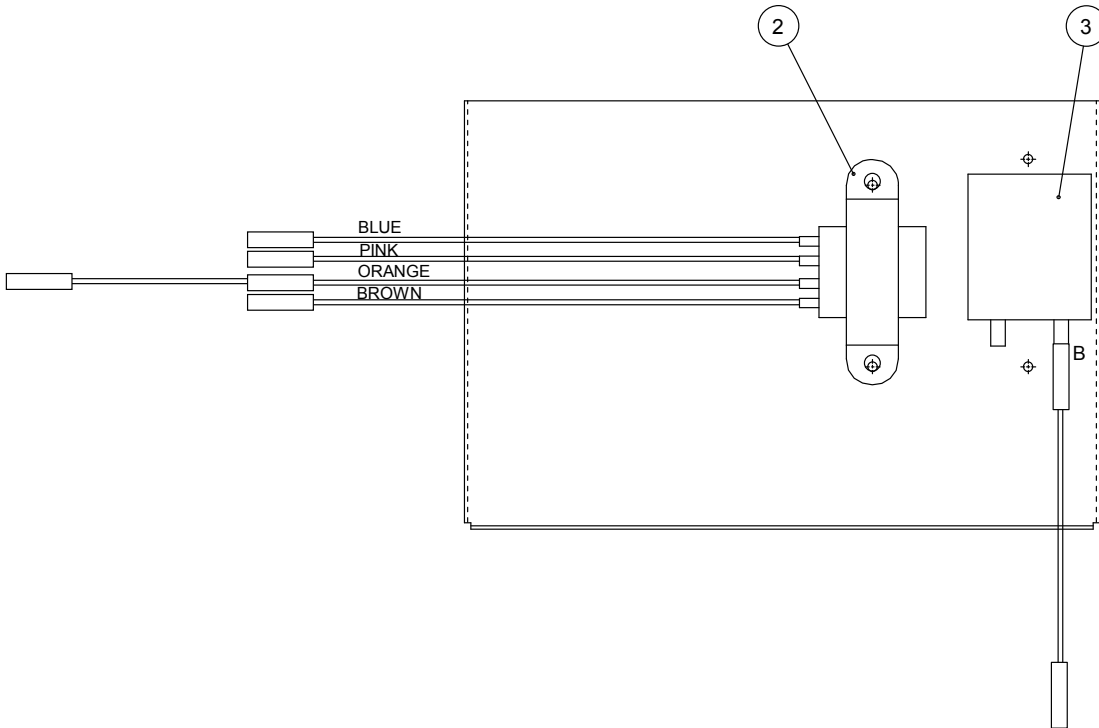
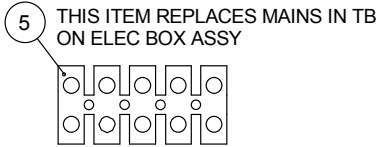

12V REMOTE HUMIDISTAT KIT
SA381005/06/07/08

2	SD336550 TRANSFORMER 0-12 (12V)	1.000
3	SD378350 RELAY 25A C/O 12V COIL	1.000
5	SD072853 15A 5 WAY TERM BLOCK	1.000

ASSEMBLY PART No	USED ON	WIRING DIAGRAM
SA381005	TTW30/33A	D372752
SA381006	TTW30/33AX	D372753
SA381007	TTW55/60A	D372752
SA381008	TTW55/60AX	D372753

12V REMOTE HUMIDISTAT CONNECTIONS

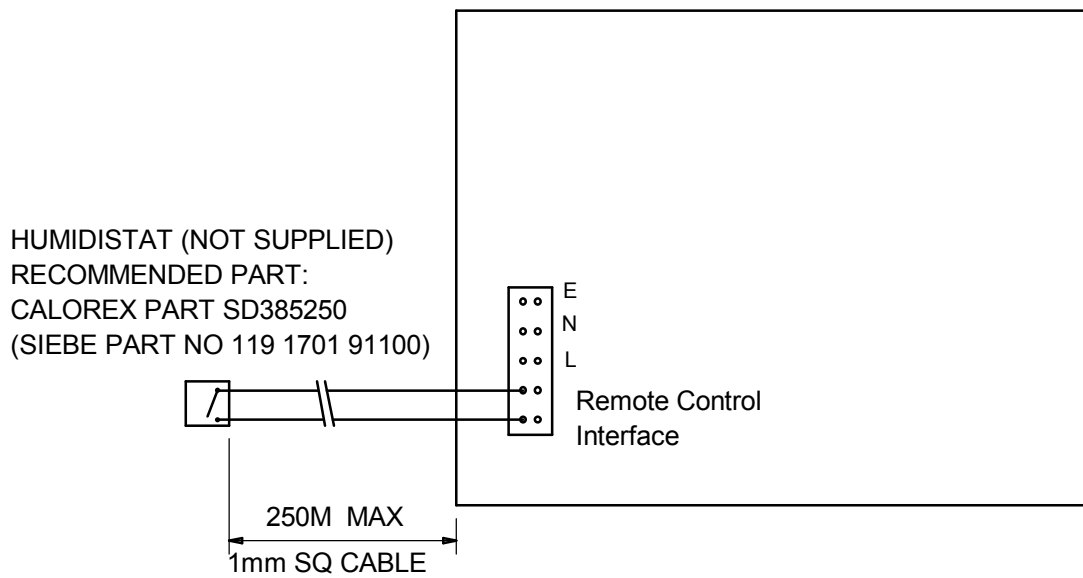

WITH REMOTE HUMIDISTAT FITTED ENSURE HUMIDISTAT
IN MACHINE IS SET FULLY CLOCKWISE (IE MAXIMUM DEHUMIDIFICATION)

7.2 LPHW ASSEMBLIES

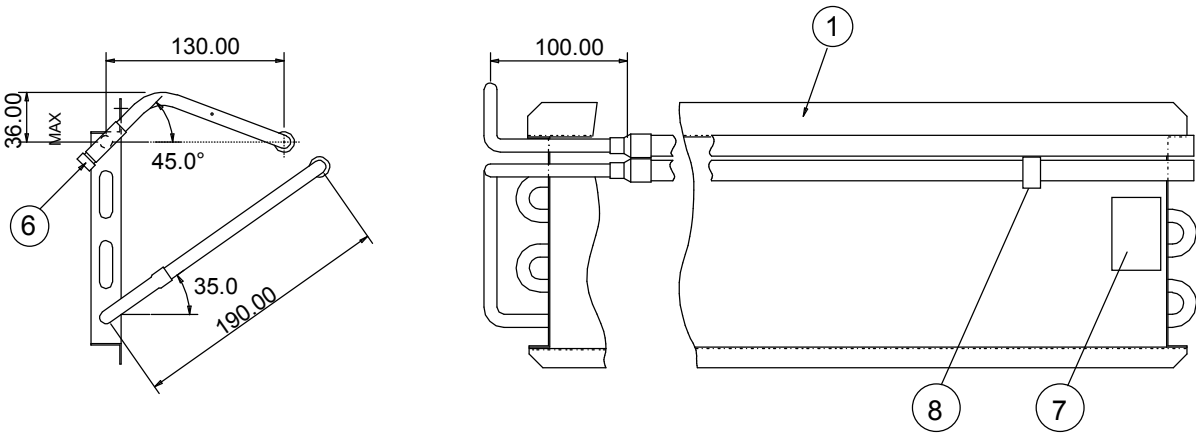

LPHW ASSY TTW30/33 SA281905

- ITEM 1 SD251750 LPHW FIN BLOCK
- ITEM 6 SD284450 AIR BLEED VALVE
- ITEM 7 SA253954 THERMOSTAT CALIBRATED TO 40°C
- ITEM 8 SD091050 PHIAL CLIP

LPHW ASSY TTW55/60 SA281906

- ITEM 1 SD251751 LPHW FIN BLOCK
- ITEM 6 SD284450 AIR BLEED VALVE
- ITEM 7 SA253954 THERMOSTAT CALIBRATED 40°C
- ITEM 8 SD091050 PHIAL CLIP

8.0 WARRANTY CONDITIONS.

The following exclusions apply to the Warranty given by Calorex Heat Pumps Ltd. No claims will be accepted if :-

1. The heat pump is in correctly sized for the application.
2. The heat pump is installed in any way that is not in accordance with the current procedures as defined by Calorex Heat Pumps Ltd.
3. The heat pump has been worked upon or is adjusted by anyone other than a person authorised to do so by Calorex Heat Pumps Ltd.
4. The air flow to and from the machine is outside the specified limits.
5. The water flow through the machine is outside the specified limits.
6. The water pH level and/or chemical balance is outside the following limits:-

Acidity	pH:	7.4 ± 0.4
Total Alkalinity, as CaCO ₃	ppm	80 -120
Total Hardness, as CaCO ₃	ppm	100-500
Total Dissolved Solids:	ppm	MAX 3000
Maximum Salt Content:	wt/wt	6%
Free Chlorine Range:	ppm	1.0 - 3.0
Superchlorination:	ppm	MAX 30 for MAX 24hrs
Bromine:	ppm	2-3
Baquacil:	ppm	25 - 50
Ozone:	ppm	0.8 - 1.0
Maximum Copper Content:	ppm	MAX 2
Aquamatic Ionic Purifier:	ppm	MAX 2
Tarn Pure Purifier:	ppm	MAX 2
Sherwood Purifier:	ppm	MAX 2

7. The heat pump has suffered frost damage.
8. The electrical supply is insufficient or in anyway incorrect

IF IN ANY DOUBT PLEASE ASK

Note:- The Reply Paid Warranty Registration Card must be returned, to ensure that the correct warranty is given. If you do not find a Registration Card with your Heat Pump please contact the Calorex Service Department giving your name, address and serial number of your heat pump. A card will be sent to you for completion.

PHONE 01621 857171



FAX 01621 850871

Email service@calorex.com

www.calorex.com

Please give MODEL NUMBER and SERIAL NUMBER of your heat pump when making technical or service enquiries. This will assist in correct diagnosis and ensure service can be provided with the minimum delay.